

U.S. MARINE CORPS TECHNICAL MANUAL
**ORGANIZATIONAL MAINTENANCE
MANUAL WITH REPAIR PARTS LIST**

FOR
RIFLE, 7.62 MM, AK-47

NSN: 1005-LL-MUS-2940

P/N TBD



MARINE CORPS SYSTEMS COMMAND
QUANTICO, VA 22134-6050

DISTRIBUTION STATEMENT C: DISTRIBUTION AUTHORIZED TO U.S. GOVERNMENT AGENCIES AND THEIR CONTRACTORS. THIS PUBLICATION IS REQUIRED FOR ADMINISTRATION AND OPERATION PURPOSES. OTHER REQUESTS FOR THIS DOCUMENT MUST BE REFERRED TO COMMANDER, MARINE CORPS SYSTEMS COMMAND (PG-13, PM, IW), QUANTICO, VA 22134-6050.

DESTRUCTION NOTICE: DESTROY BY ANY METHOD THAT WILL PREVENT DISCLOSURE OF CONTENTS OR RECONSTRUCTION OF THE DOCUMENTS.

FOR OFFICIAL USE ONLY

DECEMBER 2009
PCN 184 837001 00

INTENTIONALLY BLANK

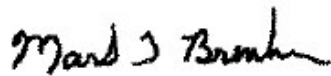
DEPARTMENT OF THE NAVY
Headquarters, U.S. Marine Corps
Washington, DC 20380-0001

31 December 2009

1. This Technical Manual (TM), authenticated for Marine Corps use and effective upon receipt, provides information on the Rifle, 7.62 mm, AK-47, NSN: 1005-LL-MUS-2940; TM 8370-50007-IN/2.
2. Submit notice of discrepancies or suggested changes on a NAVMC 10772. The NAVMC may be submitted via the Internet using website <https://pubs.ala.usmc.mil/front.htm>, scrolling down to the NAVMC 10772 Tracking Program and following instructions provided. It may also be submitted by electronic mail to mbmatcommarcorlogbases@logcom.usmc.mil, or by mailing a paper copy of NAVMC 10772 addressed to: Commanding General, Marine Corps Systems Command, Attn: Assistant Commander Acquisition and Logistics (LOG/TP), 814 Radford Blvd., Suite 20343, Albany, Georgia 31704-0343.

BY DIRECTION OF THE COMMANDANT OF THE MARINE CORPS

OFFICIAL:



MARK T. BRINKMAN
Program Manager, IW, PG-13
Marine Corps Systems Command
Quantico, Virginia

DISTRIBUTION: EDO

INTENTIONALLY BLANK

LIST OF EFFECTIVE PAGES/WORK PACKAGES

Date of issue for original manual is: 31 December 2009.

TOTAL NUMBER OF PAGES FOR FRONT AND REAR MATTER IS 18 AND TOTAL NUMBER OF WORK PACKAGES IS 27 CONSISTING OF THE FOLLOWING:

Page/WP No.	Change No.	Page/WP No.	Change No.	Page/WP No.	Change No.
Front Cover	0				
A through B	0				
a through f	0				
i through iv	0				
Chp 1 Title Page.....	0				
WP 0001 00 (2 pgs.)	0				
WP 0002 00 (4 pgs.)	0				
WP 0003 00 (2 pgs.)	0				
Chp 2 Title Page.....	0				
WP 0004 00 (2 pgs.)	0				
WP 0005 00 (2 pgs.)	0				
WP 0006 00 (14 pgs.)	0				
Chp 3 Title Page.....	0				
WP 0007 00 (2 pgs.)	0				
WP 0008 00 (14 pgs.)	0				
WP 0009 00 (4 pgs.)	0				
WP 0010 00 (2 pgs.)	0				
WP 0011 00 (4 pgs.)	0				
WP 0012 00 (6 pgs.)	0				
WP 0013 00 (28 pgs.)	0				
WP 0014 00 (2 pgs.)	0				
WP 0015 00 (4 pgs.)	0				
WP 0016 00 (2 pgs.)	0				
WP 0017 00 (4 pgs.)	0				
WP 0018 00 (2 pgs.)	0				
WP 0019 00 (2 pgs.)	0				
WP 0020 00 (2 pgs.)	0				
WP 0021 00 (8 pgs.)	0				
Chp 4 Title Page.....	0				
WP 0022 00 (2 pgs.)	0				
Chp 5 Title Page.....	0				
WP 0023 00 (2 pgs.)	0				
WP 0024 00 (2 pgs.)	0				
WP 0025 00 (4 pgs.)	0				
WP 0026 00 (4 pgs.)	0				
WP 0027 00 (12 pgs.)	0				
Index (2 pgs.)	0				

INTENTIONALLY BLANK

WARNING SUMMARY

This warning summary contains safety warnings that must be understood and applied during operation and maintenance of this equipment. Failure to observe these precautions could result in serious injury or death to personnel.



WARNING

When using carbon removing compound, avoid skin contact. Using gloves and protective equipment is required. If carbon removing compound comes in contact with skin, wash thoroughly with running water. If possible, use a lanolin-based cream after exposure to compound. Failure to follow these warnings may cause injury or death to personnel.



WARNING

Ensure that the weapon is unloaded and that the selector lever is set on SAFE before performing the following procedures. Do not keep live ammunition near the work area. Failure to follow these warnings may cause injury or death to personnel.



WARNING

Before starting an inspection, be sure to clear the weapon. Do not pull the trigger until the weapon has been cleared. Inspect the chamber to ensure that it is empty and no ammunition is in position to be chambered. DO NOT keep live ammunition in the work area. Failure to follow these warnings may cause injury or death to personnel.



WARNING

Ensure the weapon is clear prior to performing the following function checks. If the weapon fails any of the following function checks, attempt to repair it. If the weapon is beyond repair, replace it. Failure to follow these warnings may cause injury or death to personnel.



Dry cleaning solvent is flammable and toxic and should be used in a well-ventilated area. The use of rubber gloves is necessary to protect the skin when washing weapon parts. Failure to follow this warning may cause injury or death to personnel.



During general maintenance, DO NOT interchange bolt assemblies from one weapon to another without checking for the proper headspace. Refer to WP 0021 00. Failure to follow this warning may cause injury or death to personnel.



Use only cleaner, lubricant, and preservative (CLP) for cleaning and lubrication of the AK-47 rifle in all but the most severe conditions.

Improper cleaning methods and use of unauthorized cleaning solvents may injure personnel and damage equipment. Refer to TM 9-247_, *Materials Used for Cleaning, Preserving, Abrading, and Cementing Ordnance Materials and Related Materials Including Chemicals* for correct information.

Cloths or rags saturated with solvent cleaning compound must be disposed of in accordance with authorized facilities' procedures. Failure to follow these warnings may result in injury or death to personnel.



Eye shields must be worn when cleaning with a wire brush. Flying rust and metal particles may cause injury to personnel.



WARNING

Particles blown by compressed air are hazardous. Use a maximum of 30 psi when cleaning components. DO NOT exceed 15 psi nozzle pressure when drying parts with compressed air. Failure to follow these warnings may result in injury or death to personnel.



WARNING



DO NOT direct compressed air against human skin. Make sure air stream is directed away from the user and other personnel in the area. To prevent injury, the user must wear protective goggles or a face shield. Failure to follow these warnings may result in injury or death to personnel.



WARNING

Always assume that every weapon is loaded until it is determined through visual and physical inspection that it is not. Procedures for clearing and unloading the weapon are outlined in TM 8370-50007-OR/1. Failure to follow this warning may cause injury or death to personnel.



WARNING

DO NOT interchange bolt assemblies from one weapon to another without checking for the proper headspace. Failure to follow this warning may cause injury or death to personnel.



WARNING

The grooved extractor retaining pin and extractor are under spring tension.



WARNING

If the bolt is replaced, perform head space gaging. Refer to WP 0021 00.



WARNING

The auto sear is under spring tension. Use care when removing or installing the auto sear.

After pushing down the lever of the auto sear, the hammer will be under spring tension. Pulling the trigger will release the hammer and it will fall forward with force.



WARNING



The hammer spring is under spring tension and the ends may be sharp enough to puncture the skin.



WARNING

The elevation slide assembly is under spring tension. Use care when working on spring-loaded parts.



WARNING

The buttplate and trapdoor are under spring tension. Use care when removing the trap door and buttplate.



WARNING

The trap door is under spring tension. Use care when installing the trap door and buttplate.



WARNING

Ensure the weapon is clear prior to performing the following function checks. If the weapon fails any of the following function check, attempt to repair it. If the weapon is beyond repair, replace it.



WARNING

Before stowing a weapon, be sure to clear the weapon (TM-8370-50007-OR/1). Inspect the chamber to ensure it is empty and that no ammunition is in position to be chambered. Failure to follow this warning may cause injury or death to personnel.



WARNING

DO NOT store the weapon with live ammunition in either the chamber or magazine. Always assume that every weapon is loaded until it is determined through visual and physical inspection that it is not. Procedures for clearing and unloading the weapon are outlined in TM 8370-50007-OR/1. Failure to follow these warnings may cause injury or death to personnel.



WARNING

DO NOT keep live ammunition near the work area. Failure to follow this warning may cause injury or death to personnel.

CAUTION SUMMARY

CAUTION

DO NOT use a wire brush to roughen the surfaces. Use a well-ventilated area during cleaning and the application of solid film lubricant (SFL). If SFL comes in contact with moving parts or functioning surfaces of the weapon, remove the SFL immediately by washing the area with dry cleaning solvent.

CAUTION

Do not mix multiple lubricants on the same weapon. The weapon must be cleaned thoroughly when changing from one lubricant to another. Dry cleaning solvent (SD) is recommended for removing the old lubricant before changing to another lubricant.

CAUTION

Ensure the groove in the grooved extractor retaining pin is aligned with the firing pin retaining pin hole BEFORE inserting the firing pin retaining pin. Failure to do so may cause the firing pin retaining pin to lodge in the bolt permanently.

CAUTION

Letting the hammer fall uncontrolled will damage the weapon. Ensure to place a finger over the hammer before pulling the trigger in order to ride the hammer forward.

CAUTION

Ensure that all retaining pins are fully seated in the receiver and that the long leg of the auto sear is properly installed into the retaining grooves in the heads of the retaining pins.

CAUTION

The C-clip can break and deform during installation. If the C-clip becomes bent or deformed, it should be replaced. Ensure that the open end of the C-clip is facing towards the muzzle.

CAUTION

Letting the hammer fall uncontrolled will damage the weapon. Ensure to place fingers over the hammer before pulling the trigger in order to ride the hammer forward.

CAUTION

Only moderate pressure is necessary to remove the retaining pins from the receiver. If the retaining pins are difficult to remove, check to ensure that the grooves near the end of the retaining pins are not caught on the receiver wall.

CAUTION

When pushing the bolt closed during headspace gaging, be sure to use LIGHT pressure. Failure to do so may damage the weapon.

U.S. MARINE CORPS TECHNICAL MANUAL

ORGANIZATIONAL MAINTENANCE MANUAL

WITH REPAIR PARTS LIST

FOR

RIFLE, 7.62 MM, AK-47
NSN: 1005-LL-MUS-2940
P/N TBD

DISTRIBUTION STATEMENT C: DISTRIBUTION AUTHORIZED TO U.S. GOVERNMENT AGENCIES AND THEIR CONTRACTORS. THIS PUBLICATION IS REQUIRED FOR ADMINISTRATION AND OPERATION PURPOSES. OTHER REQUESTS FOR THIS DOCUMENT MUST BE REFERRED TO COMMANDER, MARINE CORPS SYSTEMS COMMAND (PG-13, PM, IW), QUANTICO, VA 22134-6050.

DESTRUCTION NOTICE: DESTROY BY ANY METHOD THAT WILL PREVENT DISCLOSURE OF CONTENTS OR RECONSTRUCTION OF THE DOCUMENTS.

	WP/Page Number
List of Effective Pages/Work Packages	A
Warning Summary	a
Caution Summary	f
How to Use This Manual	iii

CHAPTER 1 – GENERAL INFORMATION, EQUIPMENT DESCRIPTION AND DATA, AND PRINCIPLES OF OPERATION

General Information	0001 00-1
Equipment Description and Data	0002 00-1
Principles of Operation	0003 00-1

CHAPTER 2 – TROUBLESHOOTING

Troubleshooting Introduction	0004 00-1
Troubleshooting Symptom Index	0005 00-1
Troubleshooting Procedures	0006 00-1

CHAPTER 3 – ORGANIZATIONAL MAINTENANCE

Service Upon Receipt	0007 00-1
Preventive Maintenance Checks and Services (PMCS), Including Lubrication Instructions	0008 00-1
General Maintenance Instructions	0009 00-1
Disassembly of Weapon	0010 00-1
Bolt Carrier Assembly and Bolt Assembly	0011 00-1
Bolt Assembly	0012 00-1
Receiver Assembly	0013 00-1
Rear Sight Assembly	0014 00-1
Fixed Buttstock Assembly	0015 00-1
Reassembly of Weapon	0016 00-1
Function Check	0017 00-1
Stowage	0018 00-1
Preparation for Storage and Shipment	0019 00-1
Final Inspection and Function Test	0020 00-1
Gaging Procedures	0021 00-1

Table of Contents – Continued

WP / Page Number

CHAPTER 4 – AUXILIARY EQUIPMENT

Auxiliary Equipment - General0022 00-1

CHAPTER 5 – SUPPORTING INFORMATION

References0023 00-1
Expendable and Durable Items List.....0024 00-1
Tool Identification List (Includes Special Tools).....0025 00-1
Repair Parts List (RPL) Introduction0026 00-1
Repair Parts List (RPL).....0027 00-1

Index..... Index-1

HOW TO USE THIS MANUAL

INTRODUCTION

1. This manual contains operating instructions, maintenance procedures, and troubleshooting procedures for the rifle, 7.62 mm, AK-47. It is divided into five chapters.
2. This manual is written in work package format:
 - a. Chapters divide the manual into major categories of information (e.g., *General Information*, *Equipment Description and Data*, and *Principles of Operation*).
 - b. Each chapter is divided into work packages, which are identified by a 6-digit number (e.g., 0001 00, 0002 00) located at the upper right-hand corner of each page. The work package page number (e.g., 0001 00-1, 0001 00-2) is centered at the bottom of each page.
 - c. If a change package is issued to this manual, added work packages will use the 5th and 6th digits of their numbers to indicate new material. For instance, work packages inserted between WP 0001 00 and WP 0002 00 are numbered WP 0001 01, WP 0001 02.
3. This manual should be read from beginning to end to become familiar with its organization and contents before you attempt to operate or maintain the equipment.

CONTENTS OF THIS MANUAL

1. A *Warning Summary* and a *Caution Summary* are located at the beginning of this manual. Become familiar with these warnings and cautions before operating or maintaining the equipment.
2. A *Table of Contents*, located in the front of this manual, lists all chapters and work packages in the publication. If you cannot find what you are looking for in the *Table of Contents*, refer to the alphabetical *Index* at the back of the manual.
3. Chapter 1, *General Information, Equipment Description and Data, and Principles of Operation*, provides general information about the equipment, identifies the major components and systems, and describes how the components and systems work.
4. Chapter 2, *Troubleshooting*, provides symptoms and procedures pertaining to failures that could occur during operation of the AK-47.
5. Chapter 3, *Organizational Maintenance*, which includes *Preventive Maintenance Checks and Services (PMCS)*, and *General Maintenance Instructions*, provide procedures to maintain the AK-47 at the organizational level.
6. Chapter 4, *Auxiliary Equipment*, which includes information on the equipment used with the AK-47 rifle.
7. Chapter 5, *Supporting Information*, provides information pertaining to references, components listing, and an expendable and durable items list.
8. An alphabetical *Index* is located at the back of this manual.

FEATURES OF THIS MANUAL

1. This manual contains information on operating and maintaining the AK-47.
2. WARNINGS, CAUTIONS, NOTES, subject headings, and other important information are highlighted in **BOLD** print as a visual aid.

WARNING

A WARNING indicates a hazard which may result in injury or death to personnel.

CAUTION

A CAUTION is a reminder of safety practices or directs attention to usage practices that may result in damage to equipment.

NOTE

A NOTE is a statement containing information that will make the procedures easier to perform.

3. Statements and words of particular interest may be printed in CAPITAL LETTERS to create emphasis.
4. Within a procedural step, reference may be made to another chapter or work package in this manual or to another manual. These references indicate where you should look for more complete information. If you are told: "Attach the bore brush to the end of the flexible rod (WP 0014 00)", go to WP 0014 00 in this manual for instructions.
5. Illustrations are placed after, and as close to, the procedural steps to which they apply. Callouts placed on art are text or numbers.

END OF WORK PACKAGE

CHAPTER 1

GENERAL INFORMATION, EQUIPMENT DESCRIPTION AND DATA, AND PRINCIPLES OF OPERATION

INTENTIONALLY BLANK

GENERAL INFORMATION

SCOPE

1. **Type of Manual.** Organizational Maintenance Manual for the AK-47 rifle. The basic operator's procedures are outlined in TM 8370-50007-OR/1, *Operator's Manual with Components List for Rifle, 7.62 mm, AK-47*.
2. **Equipment Name and Model Number.** AK-47 rifle (NSN: 1005-LL-MUS-2940).
3. **Purpose of Equipment.** To provide personnel with the offensive and defensive capability to engage targets with small arms fire.

MAINTENANCE FORMS, RECORDS, AND REPORTS

The Marine Corps forms and procedures used for equipment maintenance will be those prescribed by the current edition of TM 4700-15/1_, *Ground Equipment Record Procedures*.

CORROSION PREVENTION AND CONTROL

Corrosion prevention on any piece of equipment is important and it is critically important for the safe functioning of a weapons system. Carry out corrosion prevention and control (CPC) in accordance with TM 4795-12/1_, *Organizational Corrosion Prevention and Control Procedures for USMC Equipment*.

While corrosion is typically associated with the rusting of metals, it can also include the deterioration of other materials such as rubber, wood, and plastic. Unusual cracking, softening, swelling, or breaking of these materials may be a corrosion problem.

DESTRUCTION INSTRUCTION TO PREVENT ENEMY USE

Follow the procedures in TM 750-244-7, *Procedures for Destruction of Equipment*, for the destruction of the AK-47 rifle and its variants to prevent enemy use.

PREPARATION FOR STORAGE AND SHIPMENT

1. Follow the procedures outlined in MCO P4450.7, *Preparation for Storage*. Prior to storing or shipping, ensure that the weapon is thoroughly cleaned as outlined in WP 0009 00.
2. Storage Procedures.
 - a. Ensure that the chamber and magazine are void of live ammunition.
 - b. Inspect the chamber and bore while applying a medium coat of cleaner, lubricant, and preservative (CLP).
 - c. Apply a light coat of CLP over all the weapon's metal surfaces to provide corrosion protection and extra lubrication. Ensure that the CLP does not come into contact with any optical devices including telescopic sight pieces.

QUALITY OF MATERIAL

All material used to repair, replace, or modify the weapon must meet the requirements of this manual. If the quality of material requirements is not stated in this manual, the material must meet the requirements of the drawings, standards, specifications, or approved engineering change proposals applicable to the subject equipment.

SAFETY, CARE, AND HANDLING

Read the *Warning Summary* and *Caution Summary* at the front of this manual and pay close attention to the warnings and cautions that appear where special care and attention are required. For ammunition care and handling, refer to PAM 385-64, *Ammunition and Explosives Safety Standards*.

LIST OF ABBREVIATIONS/ACRONYMS

Abbreviation/Acronym	Definition
be	Bale
bk	Book
bt	Bottle
CAGEC	Commercial and Government Entity Code
CLP	Cleaner, Lubricant, and Preservative
CPC	Corrosion Prevention and Control
dz	Dozen
ea	Each
fps	Feet per Second
in	Inch
LAW	Lubricant, Arctic, Weapons
LSA	Lubricant, Semi-Fluid, Automatic Weapons
m	Meter
mL	Milliliter
mm	Millimeter
N/A	Not Applicable
NSN	National Stock Number
pkg	Package
PMCS	Preventive Maintenance Checks and Services
psi	Pounds per Square Inch
pt	Pint
rds/min	Rounds per Minute
ROD	Report of Discrepancy
RPL	Repair Parts List
SD	Dry Cleaning Solvent
SFL	Solid Film Lubricant
SMR	Source, Maintenance and Recoverability
SSRI	Supply System Responsibility Items
U/M	Unit of Measure
VCI	Volatile Corrosion Inhibitor

END OF WORK PACKAGE

EQUIPMENT DESCRIPTION AND DATA

DESCRIPTION

1. **General.** The AK-47 rifle is a 7.62 x 39 mm, lightweight, air-cooled, gas-operated, magazine-fed, shoulder-fired weapon which can be selectively fired on the semi-automatic or full automatic settings.
2. **Capabilities.** Provides personnel the offensive and defensive capability to engage targets with direct small arms fire.
3. **Differences Between Models.** The AK-47 rifle can have a fixed or threaded muzzle and it can have a fixed or folding buttstock. The handguards and buttstock can be made of wood, metal, or plastic. The country of origin can be identified by the selector markings or manufacturer's markings on the right side of the receiver. Refer to Tables 2 and 3.
4. **Left Side.** The left side view of the weapon displays the muzzle, barrel, gas tube, top cover, magazine release, and pistol grip. Refer to Figure 1.

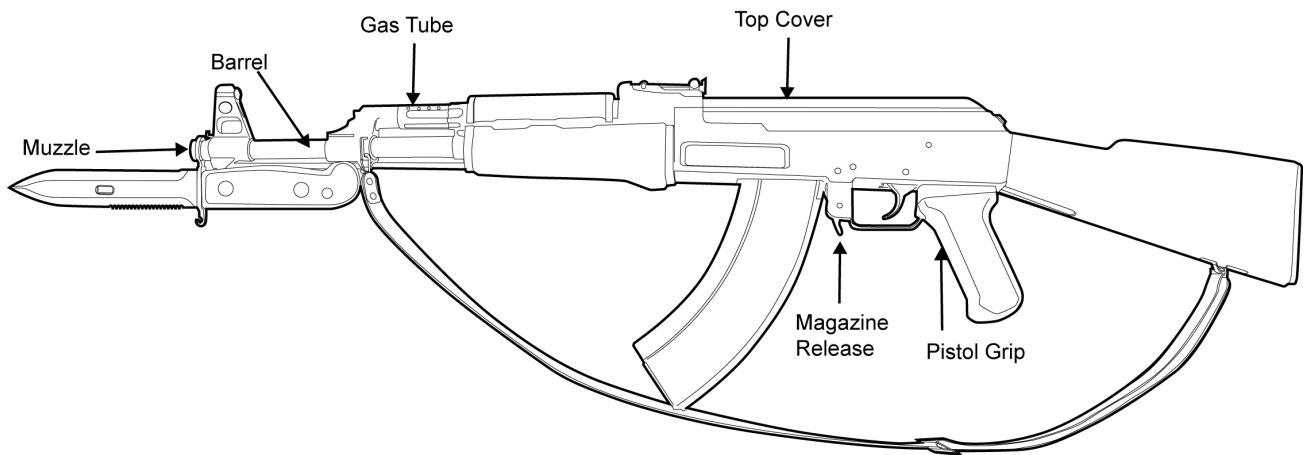


Figure 1. Left Side of the AK-47 Rifle.

5. **Right Side.** The right side view of the weapon displays the buttstock, guide rod spring lock, trigger, selector lever, charging handle, rear sight, front sight, sling, and bayonet. Refer to Figure 2.

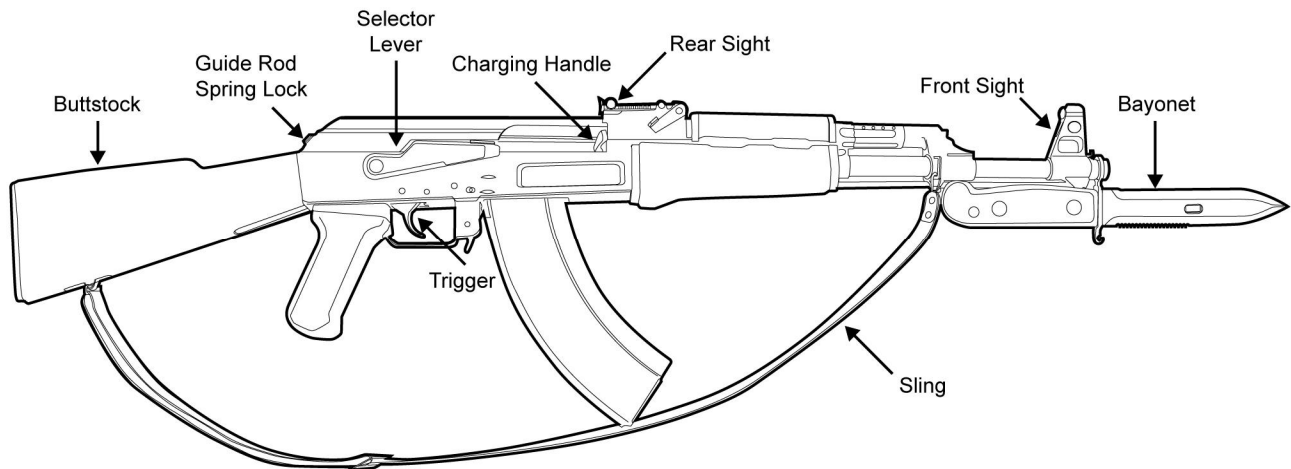


Figure 2. Right Side of the AK-47 Rifle.

LOCATION AND DESCRIPTION OF MAJOR COMPONENTS

Refer to Figure 3.

1. **Receiver and Barrel Assembly**. The receiver and barrel assembly includes the front sight assembly, gas block, gas tube, upper and lower handguards, rear sight assembly, auto sear, auto sear spring, hammer assembly, magazine release, selector lever, trigger assembly, pistol grip, and buttstock.
2. **Top Cover**. The top cover covers and protects the mechanisms housed in the receiver.
3. **Recoil Spring and Guide Rod Assembly**. The recoil spring and guide rod assembly returns the bolt carrier group to the locked position during the counter-recoil cycle.
4. **Bolt Carrier Assembly and Bolt Assembly**. The bolt carrier assembly includes the charging handle, gas piston, bolt carrier, and houses the bolt assembly, which includes the bolt, grooved extractor retaining pin, extractor, extractor spring, firing pin retaining pin, and firing pin. It carries out the cycle of operation.
5. **Magazine**. The magazine can be metal or plastic, can hold 30 rounds, and is attached to the receiver through the magazine well. It is held in place by the magazine catch. The forward motion of the bolt carrier assembly strips the cartridge from the magazine and feeds it into the chamber.
6. **Cleaning Rod**. The cleaning rod is used to conduct preventive maintenance.

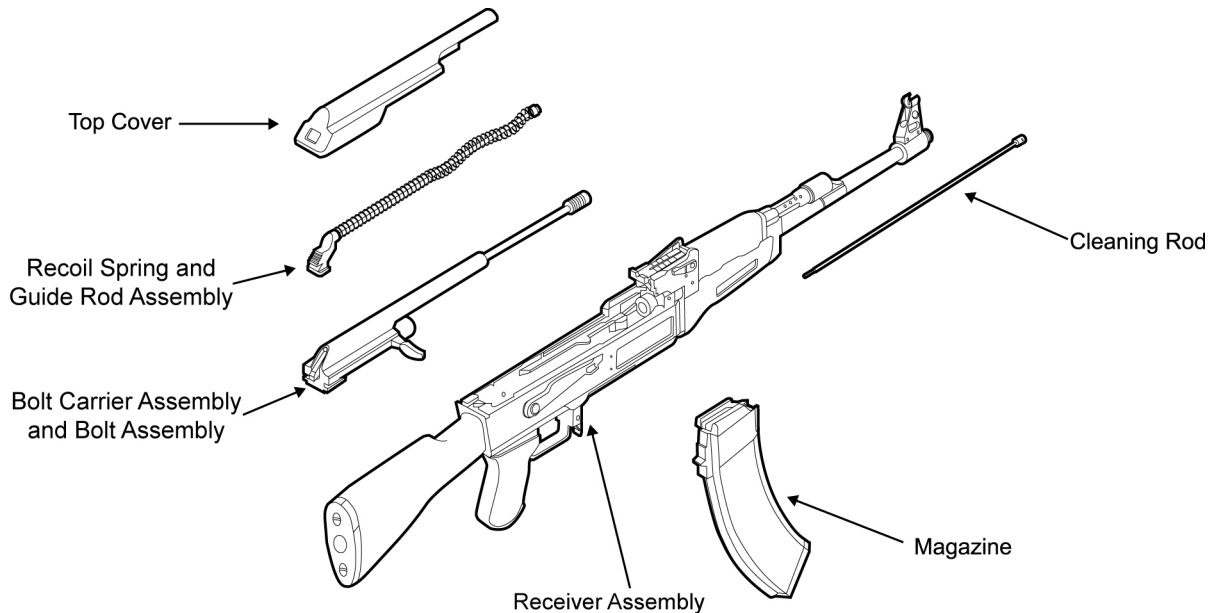


Figure 3. The AK-47 Disassembled.

EQUIPMENT DATA

Table 1. AK-47 Rifle Equipment Data.

AK-47 Rifle Equipment Data	
Caliber:	7.62 x 39 mm
Total Weight: Weapon (empty)	Approx. 9.48 lbs.
Length: Fixed Buttstock/Buttstock-Extended Buttstock Folded	Approx. 34.2 inches Approx. 27.5 inches
Rifling:	4 grooves, right-hand twist 1 turn in 12 inches
Sights: Front Rear	Adjustable sight post for elevation Adjustable windage drum for windage Leaf sight for elevation
Magazine Capacity:	30 rounds
Modes of Fire:	Semi-automatic Fully automatic
Maximum Effective Range: Semi-automatic	Approx. 400 m
Rate of Fire (cyclic):	Approx. 800 rds/min
Muzzle Velocity:	Approx. 2346 fps

Table 2. Selector Lever Markings.





































Upper or Full Auto Symbol	Lower or Semi Auto Symbol	Producer
AB	EA	Bulgaria
		China/PRC
L	D	China/PRC
30	1	Czechoslovakia
D	E	East Germany
D	E	Egypt
● ● ●	●	Finland
	1	Hungary
L	D	Iran
		Iraq
2Л	СЛ	North Korea
C	P	Poland
FA	FF	Romania
AB or AV	OA or O	Russia
R	J	Yugoslavia

Table 3. Manufacturer's Markings.

Marking	Producer	Marking	Producer	Marking	Producer
	Bulgaria		East Germany (Suhl Factory)		Russia (Izhevsk Factory)
	Bulgaria		East Germany (Ernst Thaelmann Factory)		
	Bulgaria		Egypt		
	China/PRC (Polytec)		Iraq		
 	China/PRC		North Korea		
 	China/PRC		Poland		
	China/PRC		Romania		
	China/PRC		Russia		
	China/PRC (Norinco)	 	Russia (Izhevsk Factory)		
  	China/PRC		Russia (Polyany Arsenal)		
	East Germany	 	Russia (Tula Arsenal)		
	East Germany		Russia (Tula Arsenal)		

END OF WORK PACKAGE

PRINCIPLES OF OPERATION

GENERAL

The 7.62 x 39 mm AK-47 rifle:

1. Is gas-operated.
2. Fires in either the semi-automatic (SEMI) or fully automatic (AUTO) mode.
3. Has positive locking of the bolt. The firing pin is part of the bolt assembly and cannot strike the primer until the bolt assembly is fully locked.

CYCLE OF OPERATION

The cycle of operation is similar in all small arms. Knowledge of what happens during the cycle of operation will help both the operator and the maintainer understand the cause of and remedy for various stoppages.

NOTE

The cycle of operation begins at any of the following eight steps.

1. **Eight Steps**. The cycle of operation contains eight steps:
 - a. Feeding
 - b. Chambering
 - c. Locking
 - d. Firing
 - e. Unlocking
 - f. Extracting
 - g. Ejecting
 - h. Cocking.
2. **Description of Eight Steps**. The eight steps of the cycle of operation are explained below, along with a brief description of what occurs inside the rifle during each step. Assume that a full magazine is loaded into the weapon.
 - a. **Feeding**. The magazine follower, under spring tension, feeds the top cartridge into the path of the bolt. As the bolt, held in the bolt carrier, is pushed forward by the recoil spring, the bottom of the bolt passes over the lips of the magazine, strips the top cartridge from the magazine, and pushes it into the chamber.
 - b. **Chambering**. Chambering is complete when the cartridge is fully seated in the chamber and the extractor is engaged in the extraction groove at the base of the cartridge.

Dirt or debris inside the chamber, or bent, dented, or otherwise faulty ammunition can prevent a cartridge from fully chambering or extracting.

-
- c. **Locking.** The face of the bolt strikes the rear extension of the barrel and its forward movement is stopped. As the bolt carrier continues forward, the cam recess in the bolt carrier acts on the cam on the bolt causing the bolt to rotate. As the bolt rotates, the locking lugs on the head of the bolt engage the locking recesses in the receiver. Locking is then complete.
 - d. **Firing.** When the trigger is pulled, the trigger hook(s) disengage from the hammer. The tension of the hammer spring pushes the hammer to rotate up and forward until it strikes the rear of the firing pin. The firing pin is pushed forward through the face of the bolt and strikes the primer of the round, which ignites the propellant in the cartridge. The expanding gases resulting from this explosion propel the bullet forward through the barrel.
 - e. **Unlocking.** As the round passes through the barrel and past the gas block, some of the gas (under high pressure) expands into the gas tube. This gas pushes the gas piston, which is attached to the bolt carrier, to the rear. As the bolt carrier is pushed to the rear, the cam recess in the bolt carrier acts on the cam on the bolt, causing the bolt to rotate. As the bolt rotates, the locking lugs on the head of the bolt disengage from the locking recesses in the receiver. Unlocking is then complete.
 - f. **Extracting.** The bolt carrier, holding the bolt, continues to move to the rear under pressure from the expanding gas. As the bolt moves to the rear, the bolt extractor holds the base of the cartridge against the bolt face. Extraction is complete when the front of the empty cartridge case clears the rear of the chamber.
 - g. **Ejecting.** As the bolt moves to the rear, the empty cartridge case is held by the extractor. The base of the cartridge strikes the fixed ejector located on the interior of the receiver. The extractor serves as a pivot point for the cartridge, which is deflected out of the ejection opening of the receiver.
 - a. **Cocking.** As the bolt moves to the rear, the bottom of the bolt carrier rides over the hammer. This forces the hammer to rotate down and to the rear until it is engaged by the disconnecter (if firing on SEMI) or auto sear (if firing on AUTO). When the trigger is released, the trigger hooks engage the hammer, holding it down and to the rear.

END OF WORK PACKAGE

CHAPTER 2

TROUBLESHOOTING

INTENTIONALLY BLANK

TROUBLESHOOTING INTRODUCTION

GENERAL

This section contains troubleshooting information for locating and correcting malfunctions that may occur with the AK-47 rifle.

The *Troubleshooting Symptom Index* (WP 0005 00) is a quick reference aid in troubleshooting the weapon. Table 1 in *Troubleshooting Procedures* (WP 0006 00) lists possible malfunctions, tests, or inspections, and corrective actions taken for troubleshooting the AK-47 rifle at the organizational level. Perform the tests, inspections, and corrective actions in the order shown in the table, except when the malfunction and cause are obvious. This manual cannot list all of the possible malfunctions, tests or inspections, and corrective actions of the AK-47 rifle.

END OF WORK PACKAGE

INTENTIONALLY BLANK

TROUBLESHOOTING SYMPTOM INDEX

INTRODUCTION

Refer to Table 1 in *Troubleshooting Procedures* (WP 0006 00) for malfunctions, tests or inspections, and corrective actions. The symptom index below is a quick reference of the malfunctions that are covered in the table.

Malfunction/Symptom	Troubleshooting Procedure Page
1. Failure of Magazine to Lock in Weapon	0006 00-1
2. Failure to Feed	0006 00-2
3. Failure to Chamber	0006 00-2
4. Failure to Lock	0006 00-3
5. Failure to Fire	0006 00-6
6. Failure to Unlock	0006 00-7
7. Failure to Extract	0006 00-8
8. Failure to Eject	0006 00-8
9. Failure to Cock	0006 00-9
10. Short Recoil	0006 00-10
11. Rifle Cannot be Zeroed	0006 00-11
12. Failure to Cycle with Selector Lever on AUTO.....	0006 00-12
13. Weapon Fires with Selector Lever on SAFE or when Trigger is Released with Selector Lever on SEMI	0006 00-12
14. Auto Sear Pin “Walks”	0006 00-13
15. Hammer Pin “Walks”	0006 00-13
16. Trigger Pin “Walks”	0006 00-14
17. Runaway Gun	0006 00-14

END OF WORK PACKAGE

INTENTIONALLY BLANK

TROUBLESHOOTING PROCEDURES

GENERAL

Table 1 lists possible malfunctions, tests or inspections, and corrective actions to be taken for troubleshooting the AK-47 rifle. All malfunctions are at the organizational level.

Table 1. Troubleshooting Procedures.

Malfunction	Test or Inspection	Corrective Action
1. Failure of magazine to lock in the weapon.	a. Defective magazine. b. Magazine release is dirty, corroded, or has no spring tension. Refer to Figure 1. c. Bent magazine well.	Replace the magazine. Clean the magazine release. Attempt to repair the magazine release or replace the weapon. Replace the weapon.

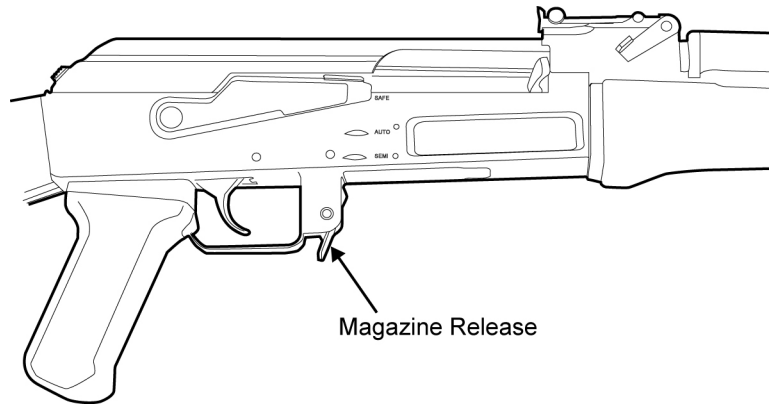


Figure 1. Magazine Release.

Table 1. Troubleshooting Procedures - Continued.

Malfunction	Test or Inspection	Corrective Action
2. Failure to feed.	a. Dirty or corroded magazine. b. Short recoil.	Disassemble and clean the magazine. Refer to TM 8370-50007-OR//1. Refer to Short Recoil in this table (# 10).
3. Failure to chamber.	a. Weak, deformed, or broken recoil spring and guide rod assembly. Refer to Figure 2. b. Short recoil.	Replace the recoil spring and guide rod assembly. Refer to WP 0010 00. Refer to Short Recoil in this table (# 10).

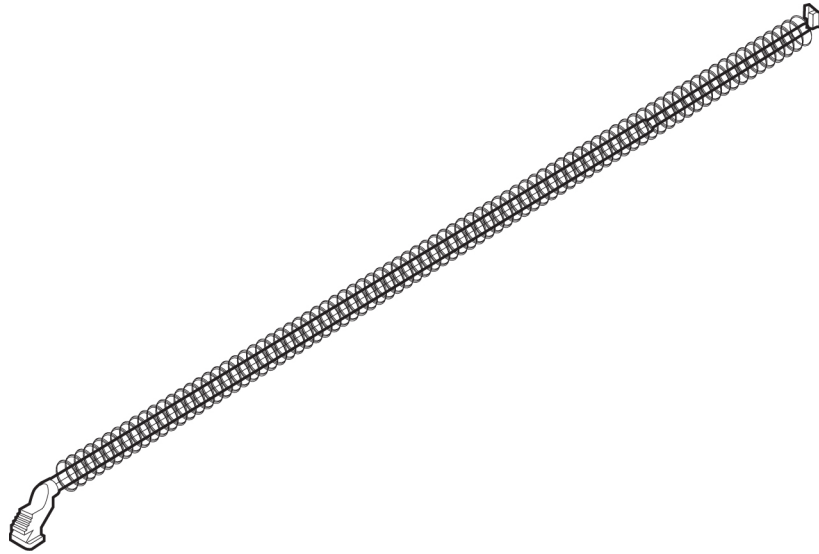


Figure 2. Recoil Spring and Guide Rod Assembly.

Table 1. Troubleshooting Procedures - Continued.

Malfunction	Test or Inspection	Corrective Action
4. Failure to lock.	a. Chamber is dirty, burred, or has an obstruction. b. Burred, dirty, or damaged bolt. Refer to Figure 3.	Clean the chamber. Remove any burrs. Remove the obstruction. Clean the bolt. Remove any burrs. Replace the bolt if necessary. Refer to WP 0012 00.

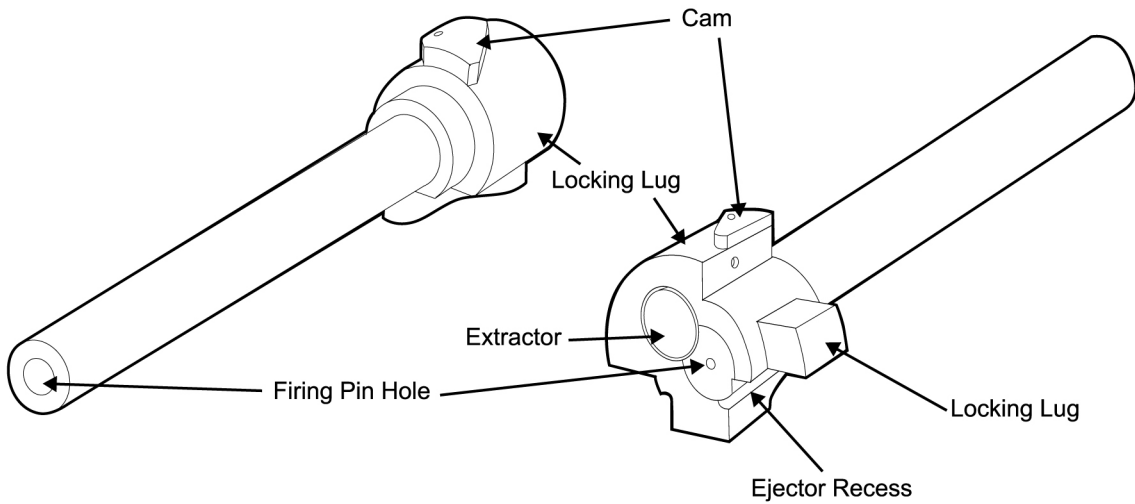


Figure 3. Opposite Views of the Bolt.

c. Improperly assembled extractor assembly. Refer to Figure 4.

Assemble the extractor assembly correctly. Refer to WP 0012 00.

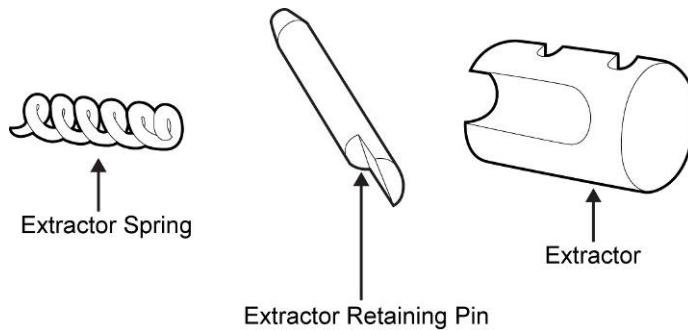


Figure 4. Extractor Assembly.

Table 1. Troubleshooting Procedures - Continued.

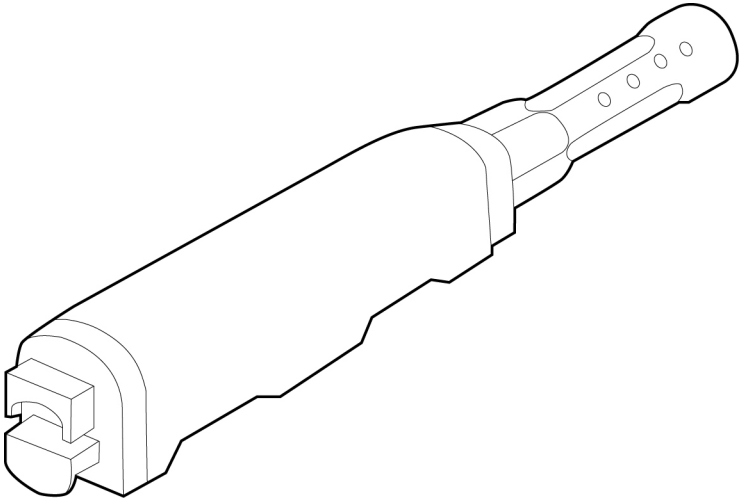
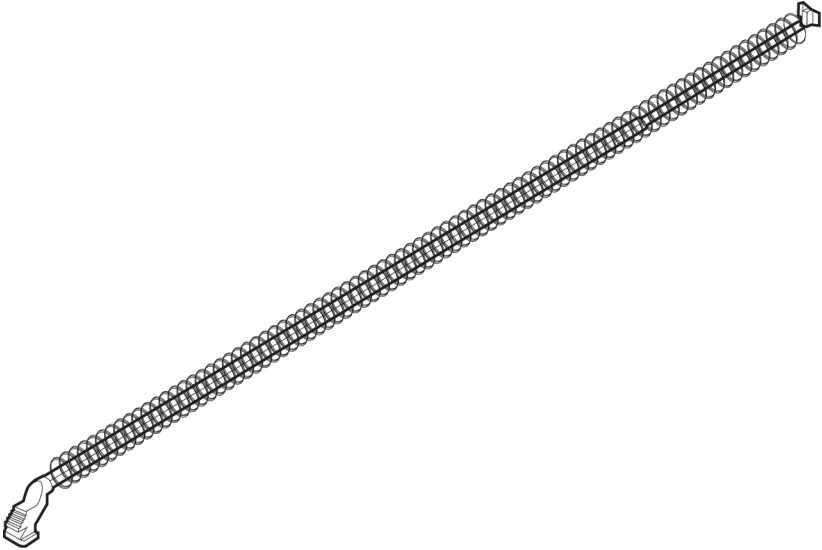
Malfunction	Test or Inspection	Corrective Action
4. Failure to lock - Cont.	d. Defective gas tube. Refer to Figure 5.	Replace the gas tube. Refer to WP 0010 00.
<p>NOTE</p> <p>Pits or holes in the gas tube may be caused by ammunition which is corrosive due to old age or poor manufacture.</p> 		
<p>Figure 5. Gas Tube in Handguard.</p>		
	e. Weak or broken recoil spring and guide rod assembly. Refer to Figure 6.	Replace the recoil spring and guide rod assembly. Refer to WP 0010 00.
		
<p>Figure 6. Recoil Spring.</p>		

Table 1. Troubleshooting Procedures - Continued.

Malfunction	Test or Inspection	Corrective Action
4. Failure to lock - Cont.	f. Bolt carrier assembly (gas piston and bolt carrier) is dirty, burred, or damaged Refer to Figure 7.	Clean bolt carrier assembly. Remove any burrs. Replace if necessary. Refer to WP 0011 00.

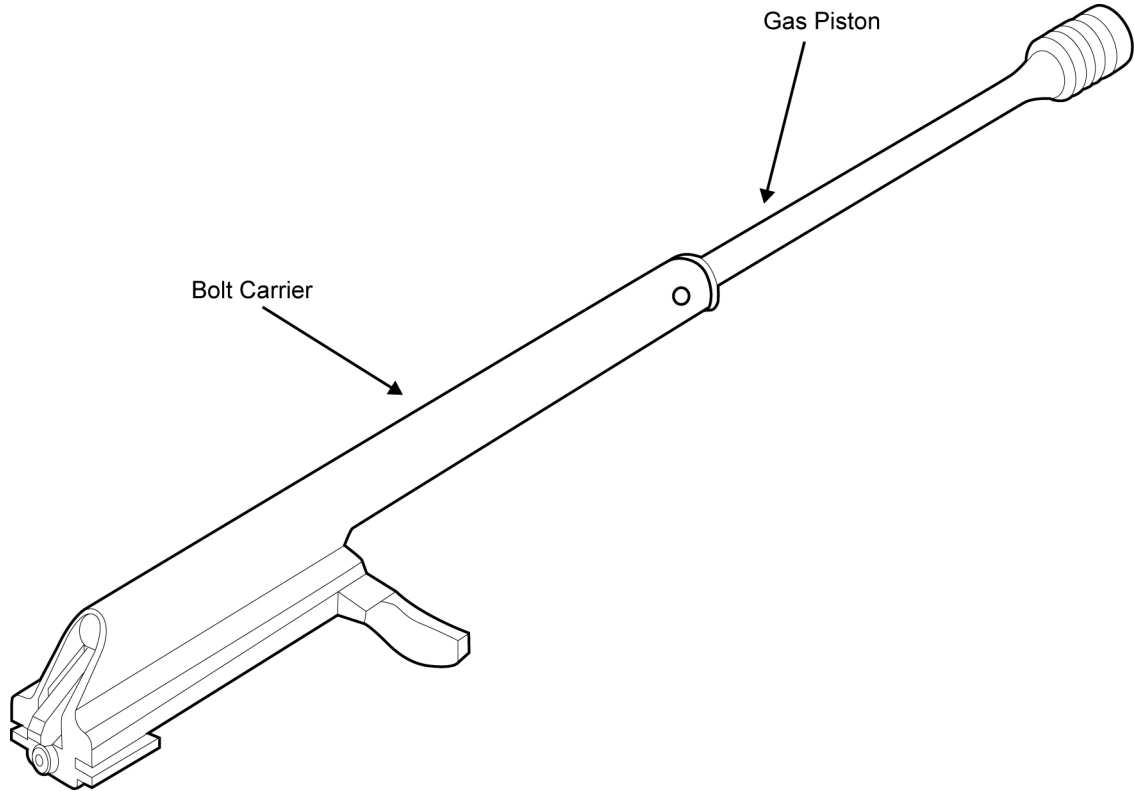


Figure 7. Bolt Carrier Assembly.

Table 1. Troubleshooting Procedures - Continued.

Malfunction	Test or Inspection	Corrective Action
5. Failure to fire.	a. Carbon buildup in bolt assembly. b. Firing pin retaining pin incorrectly installed. c. Broken, defective, or missing firing pin retaining pin. Refer to Figure 8.	Disassemble and clean the bolt assembly. Refer to WP 0012 00. Correctly install the firing pin retaining pin. Refer to WP 0012 00. Replace the firing pin retaining pin. Refer to WP 0012 00.

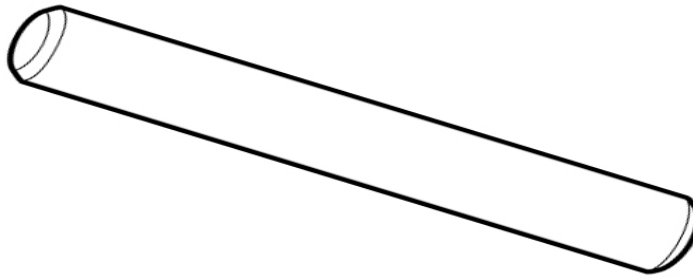


Figure 8. Firing Pin Retaining Pin.

d. The firing pin is incorrectly installed.	Correctly install the firing pin. Refer to WP 0012 00.
e. Broken or chipped firing pin. Refer to Figure 9.	Replace the firing pin. Refer to WP 0012 00.

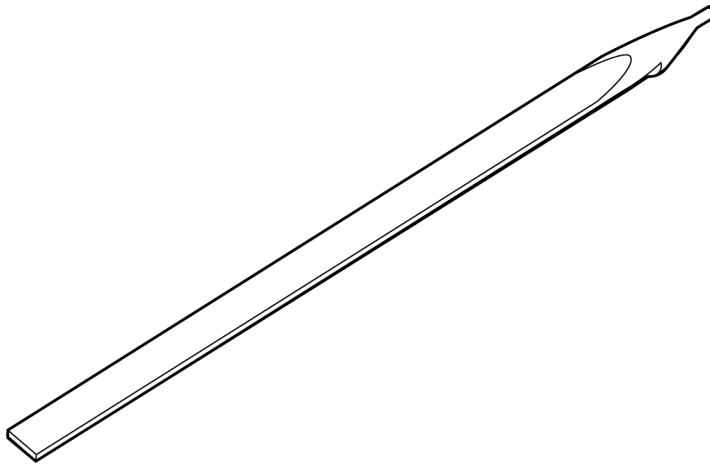


Figure 9. Firing Pin.

Table 1. Troubleshooting Procedures - Continued.

Malfunction	Test or Inspection	Corrective Action
5. Failure to fire - Cont.	f. Improperly assembled weapon. g. Broken hammer or hammer spring. h. Hammer/trigger improperly assembled. i. Hammer spring improperly installed.	Assemble the weapon correctly. Refer to TM 8370-50007-OR/1, WP 0011 00, WP 0012 00, and WP 0013 00. Replace the hammer or hammer spring. Refer to WP 0013 00. Assemble the hammer/trigger correctly. Refer to WP 0013 00. Install the hammer spring correctly. Refer to WP 0013 00.
6. Failure to unlock.	a. Burred bolt assembly. b. Burred bolt carrier assembly (gas piston and bolt carrier). Refer to Figure 10.	Remove burrs or replace the bolt assembly. Refer to WP 0012 00. Remove burrs or replace the bolt carrier assembly. Refer to WP 0011 00.

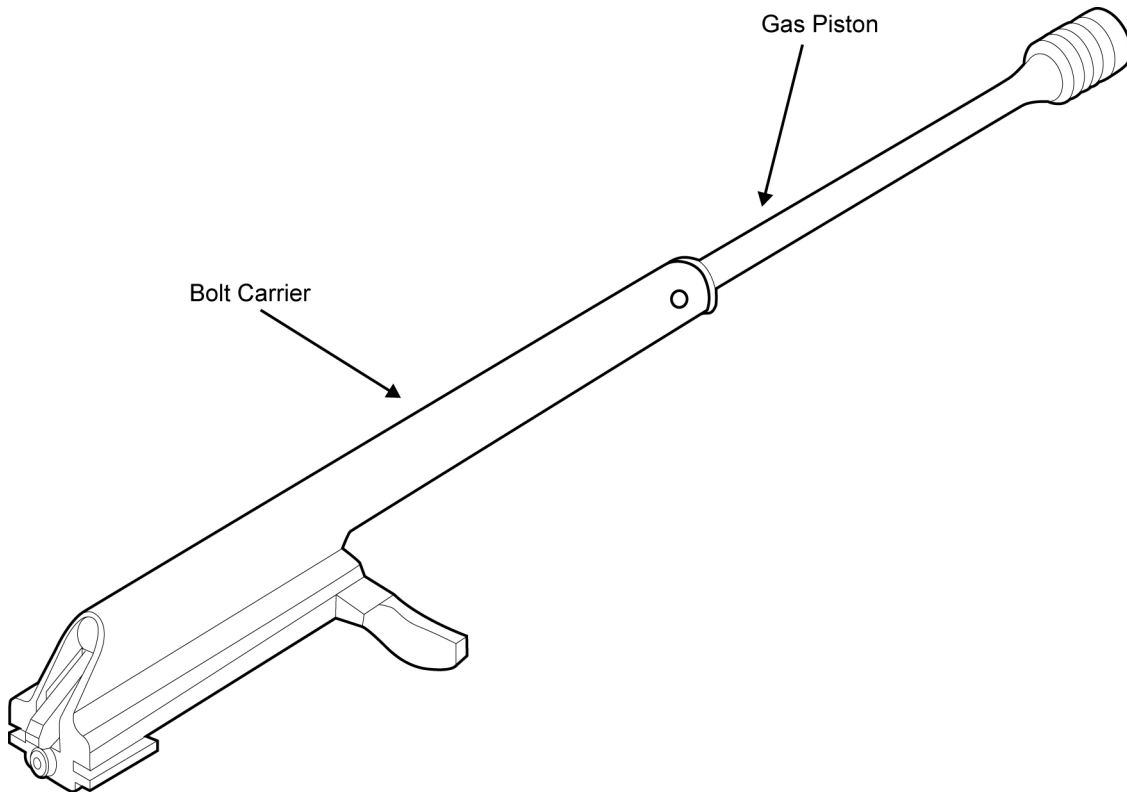


Figure10. Bolt Carrier Assembly.

Table 1. Troubleshooting Procedures - Continued.

Malfunction	Test or Inspection	Corrective Action
7. Failure to extract.	a. Defective extractor retaining pin, extractor, and/or extractor spring. Refer to Figure 11. b. A cartridge is lodged in the barrel due to bad ammunition or barrel erosion. c. Short recoil.	Replace the extractor retaining pin, extractor, and/or extractor spring. Refer to WP 0012 00. Remove the cartridge. Check the quality of ammunition. Gage the barrel to check for erosion. Replace the weapon if necessary. Refer to WP 0021 00 Refer to Short Recoil in this table (# 10).

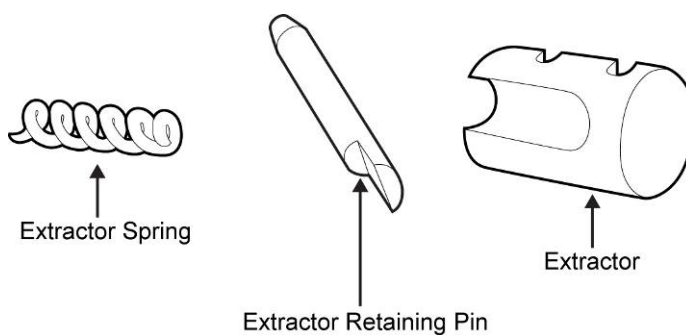


Figure 11. Extractor Spring, Extractor Retaining Pin, and Extractor.

8. Failure to eject.	a. Defective cartridge ejector. Refer to Figure 12. b. Short recoil.	Attempt to repair. Replace the weapon if necessary. Refer to Short Recoil in this table (# 10).
----------------------	---	--

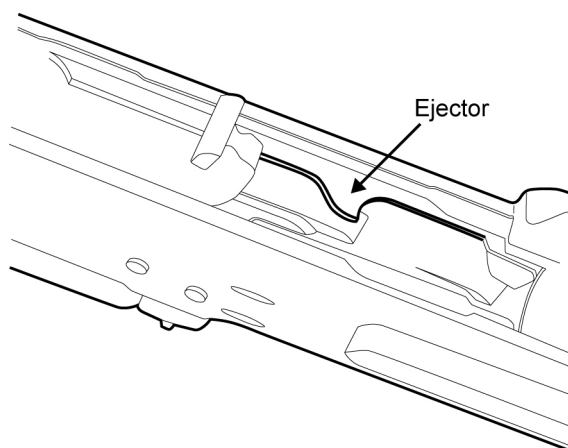


Figure 12. Ejector.

Table 1. Troubleshooting Procedures - Continued.

Malfunction	Test or Inspection	Corrective Action
9. Failure to cock.	a. Short recoil. b. Worn or broken hammer spring. Refer to Figure 13. c. Worn or broken trigger. d. Worn or broken hammer.	Refer to Short Recoil in this table (# 10). Replace hammer spring. Refer to WP 0013 00. Replace the trigger. Refer to WP 0013 00. Replace the hammer. Refer to WP 0013 00.

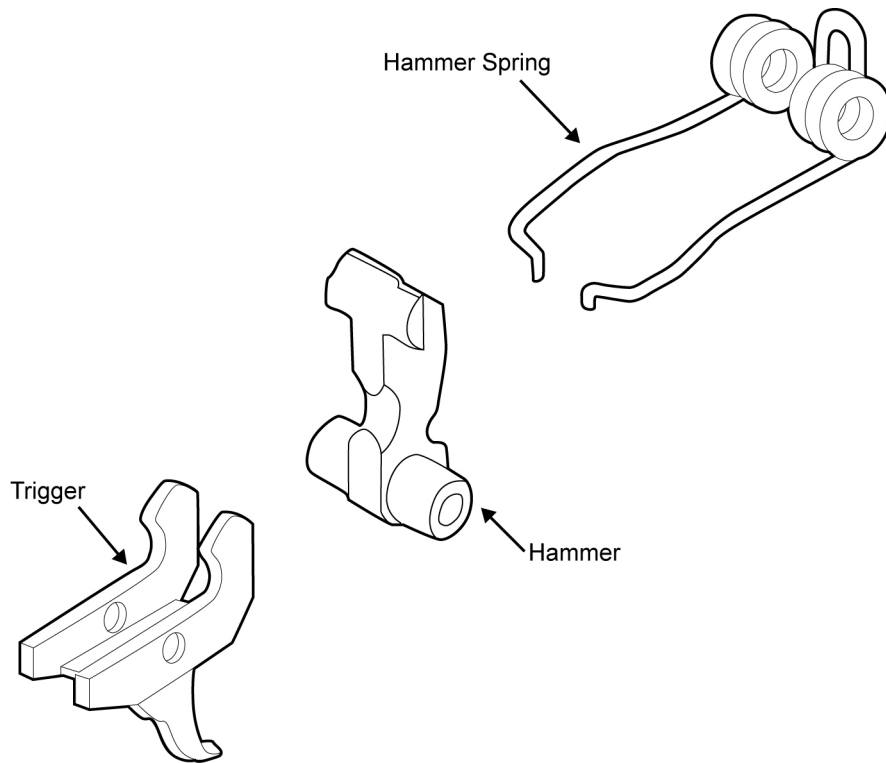



Figure 13. Trigger, Hammer, and Hammer Spring.

Table 1. Troubleshooting Procedures - Continued.

Malfunction	Test or Inspection	Corrective Action
10. Short recoil.	<p>a. Defective recoil spring and guide rod assembly.</p> <p>b. Dirty gas block, gas tube, recoil spring and guide rod assembly, or bolt carrier assembly (gas piston and bolt carrier).</p> <p>c. Excessive gas leakage caused by defective gas tube or gas block. Pitting due to use of corrosive ammunition</p> <p>d. Weak or broken gas piston.</p> <p>e. Gas selector is in the wrong position.</p> <div style="text-align: center;">  <p>WARNING</p> <p>When using carbon removing compound, wearing gloves and protective equipment is required. Avoid contact with skin. If carbon removing compound comes in contact with skin, wash thoroughly with running water, and apply a lanolin-based cream, if possible. Failure to follow this warning may cause injury or death to personnel.</p> </div> <p>f. Carbon build-up in barrel/gas block.</p>	<p>Replace recoil spring and guide rod assembly. Refer to WP 0010 00.</p> <p>Clean and lubricate with CLP. Refer to WP 0010 00 and WP 0013 00.</p> <p>Replace the gas tube. If the gas block is defective, replace the weapon. Refer to TM 8370-50047-OR/1.</p> <p>Replace the bolt carrier assembly. Refer to WP 0010 00.</p> <p>Rotate the gas selector. Refer to WP 0013 00.</p> <p>Remove carbon build-up by soaking the barrel in carbon removing compound.</p>

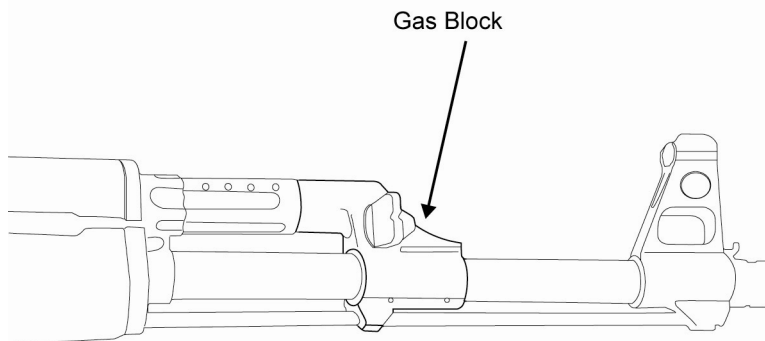


Figure 14. Gas Block.

Table 1. Troubleshooting Procedures - Continued.

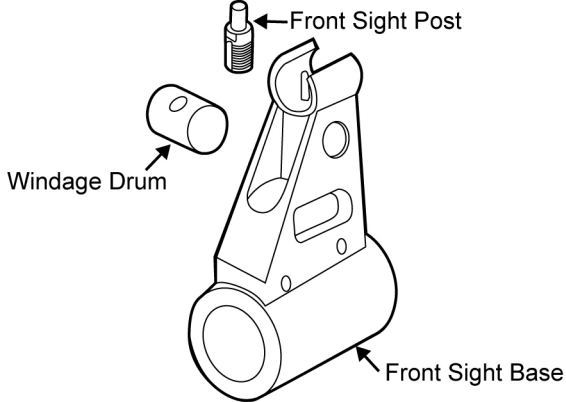
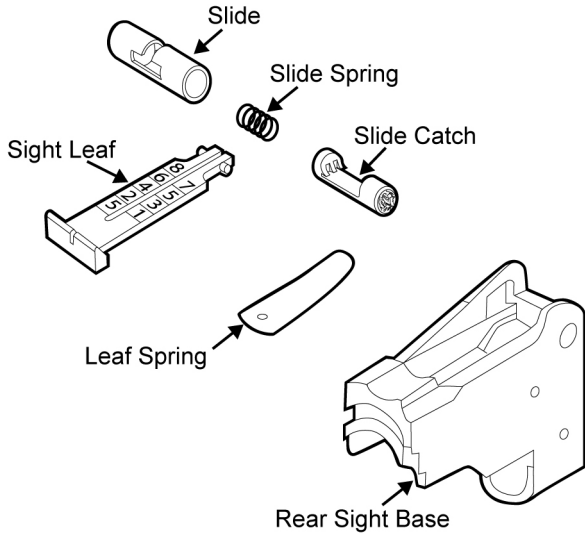
Malfunction	Test or Inspection	Corrective Action
11. Rifle cannot be zeroed.	a. Defective front sight post. Refer to Figure 15.	Remove the front sight post. If damaged, replace. Refer to WP 0013 00.
 <p>The diagram shows a perspective view of the front sight assembly. A cylindrical 'Front Sight Post' is shown being inserted into the top of the 'Front Sight Base'. A 'Windage Drum' is shown as a separate cylindrical component to the left of the base.</p>		
<p>Figure 15. Front Sight Assembly.</p>		
	b. Defective or bent barrel. c. For elevation: defective rear sight. Refer to Figure 16. d. For elevation: improperly assembled rear sight. Refer to Figure 16.	Replace weapon. Repair the rear sight as required. Refer to WP 0013 00. Properly assemble the rear sight. Refer to WP 0013 00 and WP 0014 00.
 <p>The diagram shows the components of the rear sight assembly. A 'Slide' is shown at the top left. Below it is a 'Slide Spring'. To the right is a 'Slide Catch'. Below these is a 'Sight Leaf' with 'WINDAGE' and 'ELEVATION' markings. Below the sight leaf is a 'Leaf Spring'. At the bottom right is the 'Rear Sight Base'.</p>		
<p>Figure 16. Rear Sight Assembly.</p>		

Table 1. Troubleshooting Procedures - Continued.

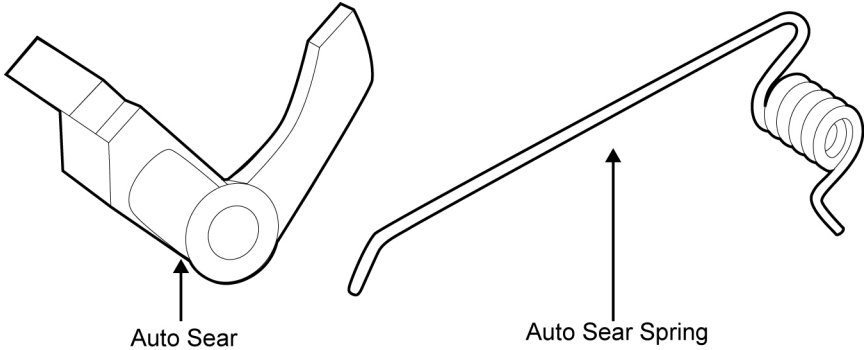
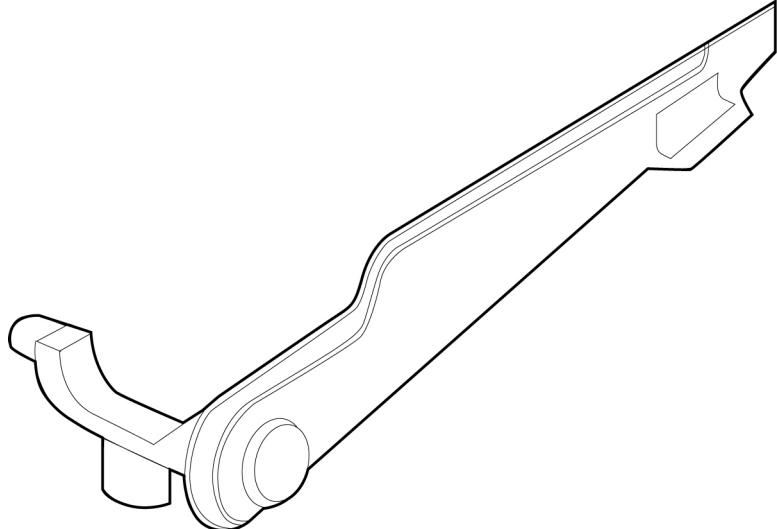
Malfunction	Test or Inspection	Corrective Action
12. Failure to cycle with selector lever on AUTO.	a. Broken or worn auto sear or auto sear spring. Refer to Figure 17.	Replace the auto sear or auto sear spring. Refer to WP 0013 00.
 <p data-bbox="527 829 1047 871">Figure 17. Auto Sear and Auto Sear Spring.</p>		
13. Weapon fires with selector lever on SAFE or when trigger is released with selector lever on SEMI.	b. Defective selector lever. Refer to Figure 18.	Replace the selector lever. Refer to WP 0013 00.
	c. Short recoil.	Refer to Short Recoil in this table (# 10).
	a. Defective selector lever. Refer to Figure 18. b. Worn or broken trigger.	Replace the selector lever. Refer to WP 0013 00. Replace the trigger. Refer to WP 0013 00.
 <p data-bbox="625 1806 950 1848">Figure 18. Selector Lever.</p>		

Table 1. Troubleshooting Procedures - Continued.

Malfunction	Test or Inspection	Corrective Action
<p>14. Auto sear retaining pin “walks” or works loose during firing, or auto sear retaining pin is very easy to push out of receiver.</p>	<p>a. Worn or broken auto sear retaining pin or auto sear spring. Refer to Figure 19.</p> <p>b. Long leg of auto sear spring set incorrectly into groove in the auto sear retaining groove.</p>	<p>Replace the auto sear retaining pin or the auto sear spring. Refer to WP 0013 00.</p> <p>Install the long leg of the auto sear spring correctly. Refer to WP 0013 00.</p>

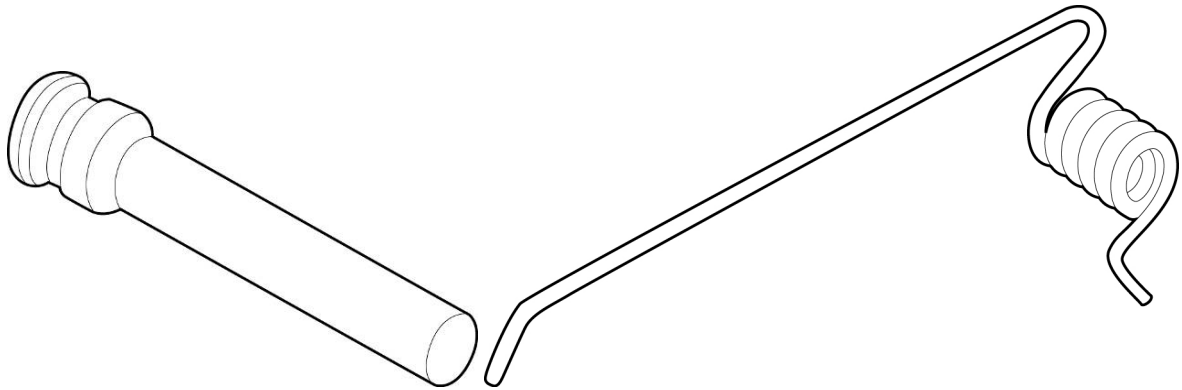


Figure 19. Auto Sear Retaining Pin and Auto Sear Spring.

<p>15. Hammer retaining pin “walks” or works loose during firing, or hammer retaining pin is very easy to push out of receiver.</p>	<p>a. Worn or broken hammer retaining pin or auto sear spring. Refer to Figure 20.</p> <p>b. Long leg of auto sear spring set incorrectly into hammer retaining pin groove.</p>	<p>Replace the hammer retaining pin or auto sear spring. Refer to WP 0013 00.</p> <p>Install the long leg of the auto sear spring correctly. Refer to WP 0013 00.</p>
---	---	---

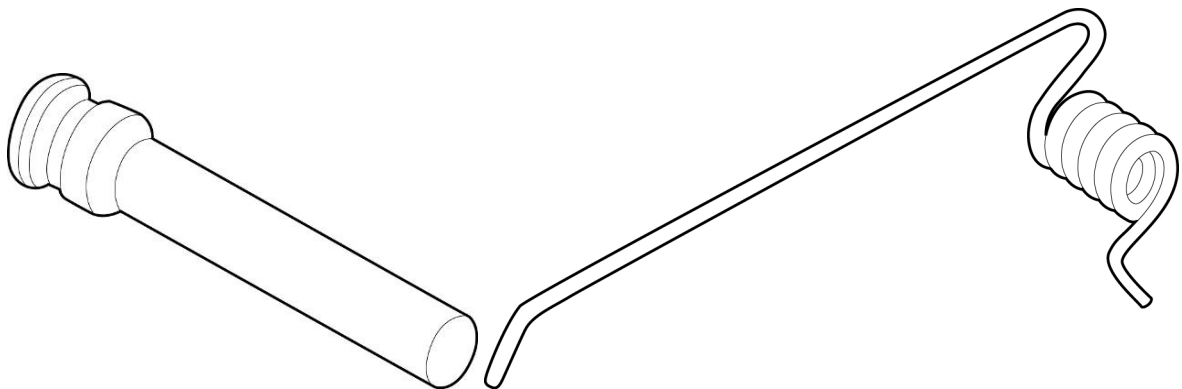


Figure 20. Hammer Retaining Pin and Auto Sear Spring.

Table 1. Troubleshooting Procedures - Continued.

Malfunction	Test or Inspection	Corrective Action
16. Trigger retaining pin "walks" or works loose during firing, or trigger retaining pin is very easy to push out of receiver.	a. Worn or broken trigger retaining pin or auto sear spring. Refer to Figure 21. b. Long leg of auto sear spring set incorrectly into trigger retaining pin groove.	Replace the trigger retaining pin or auto sear spring. Refer to WP 0013 00. Install the long leg of the auto sear spring correctly. Refer to WP 0013 00.

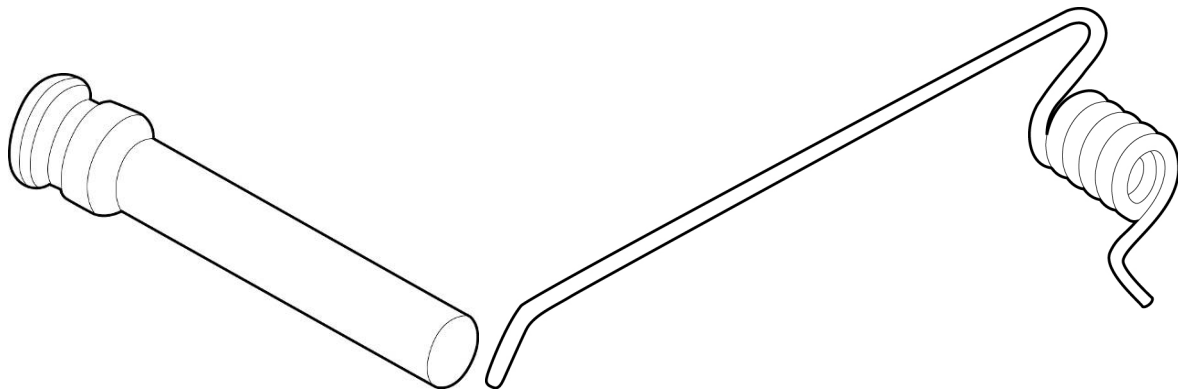


Figure 21. Trigger Retaining Pin and Auto Sear Spring.

17. Runaway gun.	a. Defective auto sear. Refer to Figure 22. b. Worn or defective disconnecter. Refer to Figure 22. c. Defective hammer or the top of hammer is worn. Refer to Figure 22.	Replace the auto sear. Refer to WP 0013 00. Replace the disconnecter. Refer to WP 0013 00. Replace the hammer. Refer to WP 0013 00.
------------------	--	---

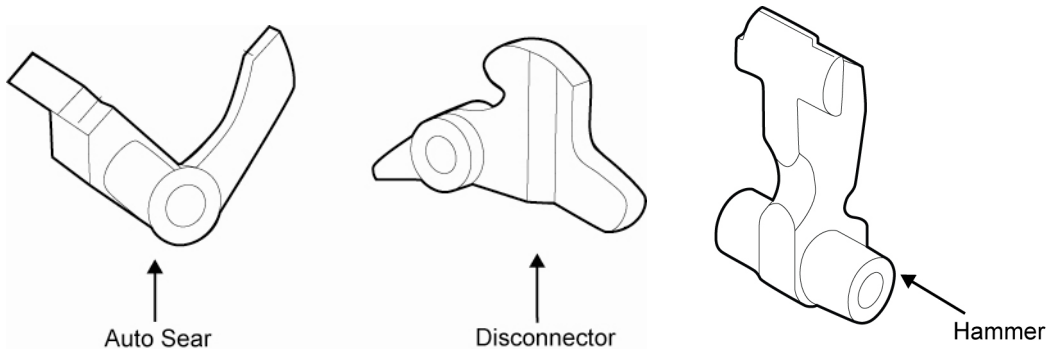


Figure 22. Auto Sear, Disconnecter, and Hammer.

CHAPTER 3
ORGANIZATIONAL MAINTENANCE

INTENTIONALLY BLANK

SERVICE UPON RECEIPT

GENERAL

1. Inspect the weapon for damage incurred during shipment. If the weapon has been damaged, report the damage on SF 364, *Report of Discrepancy (ROD)*.
2. Check the weapon against the packing slip to see if the shipment is complete.
3. Check to see if the weapon has been modified.
4. Check the weapon for damage upon its receipt. Perform limited technical inspection as outlined in Table 1 of this work package.

Table 1. Service Upon Receipt.

Location	Item	Action	Remarks
Container	<ol style="list-style-type: none"> 1. AK-47 2. Supply system responsibility items (SSRI) 3. Barrel assembly 	<ol style="list-style-type: none"> a. Remove weapon from containers. b. Inspect the weapon for damage incurred during shipment. c. Check the weapon against the packing list to see if the shipment is complete. <p>Check for missing items.</p> <p>If volatile corrosion inhibitor (VCI) is in the barrel, remove and discard.</p>	<p>If the weapon has been damaged, report damage on SF 364..</p> <p>Report all discrepancies</p> <p>Refer to TM 8370-50007 OR/1.</p>
AK-47 rifle	<ol style="list-style-type: none"> 1. All parts 2. Magazine 	<ol style="list-style-type: none"> a. Field strip the weapon and inspect for missing, damaged, and rusted or corroded parts. b. Clean and lubricate c. Reassemble. d. Function check. e. Check to see if the weapon has been modified. f. Conduct initial gaging. <p>Check for positive retention of magazine.</p>	<p>Refer to TM 8370-50007 OR/1.</p> <p>Refer to TM 8370-50007 OR/1.</p> <p>Refer to TM 8370-50007 OR/1.</p> <p>Refer to WP 0017 00.</p> <p>Report all modifications.</p> <p>Refer to WP 0021 00</p> <p>Refer to TM 8370-50007 OR/1.</p>

END OF WORK PACKAGE

INTENTIONALLY BLANK

PREVENTIVE MAINTENANCE CHECKS AND SERVICES (PMCS), INCLUDING LUBRICATION INSTRUCTIONS

GENERAL

This work package contains procedures and instructions necessary to perform organizational preventive maintenance checks and services (PMCS), along with disassembly and reassembly procedures required for corrective maintenance for the AK-47 rifle.

1. **Organizational Maintenance.** Organizational maintenance is performed at the using unit beyond the capabilities of the operator as identified in TM 8370-50007-OR/1. Organizational maintenance is authorized to service, replace, and adjust the parts and assemblies covered in the Organizational portion of this manual.
2. **Intermediate through Depot Maintenance.** This is not applicable to this platform. All maintenance is performed at the organizational level or the weapon is replaced.
3. **Special Tools; Test, Measuring, and Diagnostic Equipment (TMDE); and Support Equipment.** Special tools and TMDE required for support are listed in WP 0025 00. There are no fabricated tools for this weapons.
4. **Repair Parts.** Repair parts are listed and illustrated in WP0027 00.



WARNING

Ensure that the weapon is unloaded and that the selector lever is set on SAFE before performing the following procedures. Do not keep live ammunition near the work area. Failure to follow these warnings may cause injury or death to personnel.

NOTES

PMCS is to be performed every 90 days to keep the weapon ready for use. If the weapon has not been used for 90 days, PMCS described in the operator's manual (TM 8370-50007-OR/1) should also be performed.

Solid film lubricant (SFL) is authorized to be used as a touch up for the exterior protective finish on the AK-47.

5. **General.** The PMCS procedures are contained in the following table. They are arranged in logical sequence requiring a minimum amount of time and motion on the part of the persons performing them and are arranged so that there will be minimum interference between the persons performing simultaneous checks on the same end item.
6. **Item Number Column.** This column describes checks and services numbered in disassembly sequence.
7. **Interval Column.** This column states the designated interval when each check is to be performed.
8. **Item to Check/Service Column.** This column lists the items to be checked or serviced.

- 9. **Procedure Column.** This column contains a brief description of the procedure by which the check is to be performed. It contains all the information required to accomplish the checks and services.
- 10. **Not Fully Mission Capable if Column.** This column states which faults will prevent the weapon from being capable of performing its primary mission. The weapon should not be used if it meets any of the faults listed in this column.
- 11. **Other Table Entries.** Observe all WARNINGS, CAUTIONS, and NOTES.

Table 1. Preventive Maintenance Checks and Services for the AK-47 Rifle.


Item No.	Interval	Location or Item to Check/Service	Procedure	Not Fully Mission Capable if:
			<div style="text-align: center;">  <p>WARNING</p> </div> <p>Before starting an inspection, be sure to clear the weapon. Do not pull the trigger until the weapon has been cleared. Inspect the chamber to ensure that it is empty and no ammunition is in position to be chambered. DO NOT keep live ammunition in the work area. Failure to follow these warnings may cause injury or death to personnel.</p> <p style="text-align: center;">NOTES</p> <p>An inactive weapon is a weapon that has been stored in an arms room for a period of 90 days without use.</p> <p>Inactive weapons should receive quarterly PMCS unless inspection reveals more frequent servicing is necessary.</p> <p>If the unit armorer detects corrosion on a weapon prior to the end of the 90 day period, the PMCS should be performed immediately.</p> <p>SFL is the authorized touch up for the AK-47 rifle.</p>	

Table 1. Preventive Maintenance Checks and Services for the AK-47 Rifle - Continued.

Item No.	Interval	Location or Item to Check/Service	Procedure	Not Fully Mission Capable if:
1	Quarterly	Magazine (Serviceability Check)	<p>a. Disassemble (TM 8370-50007-OR/1). Inspect the magazine body for bulges, dents, or damaged feeder lips. Inspect the spring and follower for bends, kinks, or damage. Replace the magazine if any of these conditions exist. Refer to Figure 1.</p> <p>b. Reassemble the magazine and check for binding when depressing and releasing the follower. Replace the magazine if the follower binds. Refer to Figure 1.</p>	<p>A magazine is not available for use with the rifle.</p> <p>(1) The body is dented or feeder lips on top of the body are damaged. The spring is damaged or has flat spots.</p> <p>(2) The follower binds.</p>

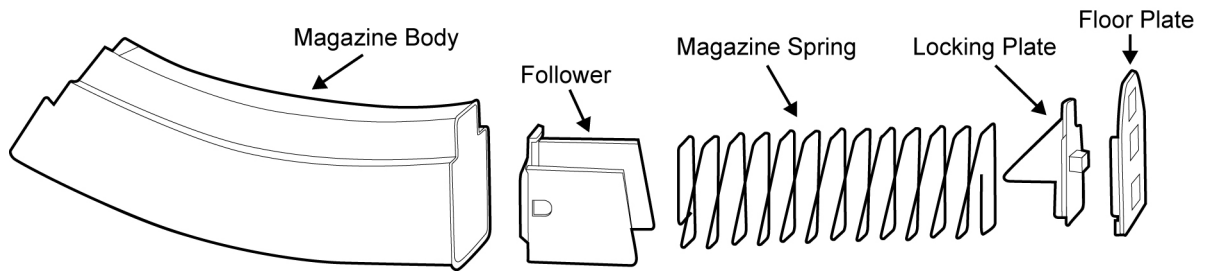



Figure 1. Magazine Components.

Table 1. Preventive Maintenance Checks and Services for the AK-47 Rifle - Continued.

Item No.	Interval	Location or Item to Check/Service	Procedure	Not Fully Mission Capable if:
2	Quarterly	Selector Lever, Function Check Selector Lever - SEMI - SAFE - SEMI	 <p>WARNING</p> <p>Ensure the weapon is clear prior to performing the following function checks. If the weapon fails any of the following function checks, attempt to repair. If beyond repair, replace the weapon.</p> <p>a. Pull and hold the charging handle to the rear. Check that the chamber is clear. Let the bolt carrier close forward. Refer to Figure 2.</p> <p>b. Leave the hammer in the cocked position. Do not pull the trigger.</p> <p>a. Place the selector lever in SAFE position.</p> <p>b. Pull the trigger. The hammer should not fall.</p> <p>a. Place the selector lever in SEMI position.</p> <p>b. Pull the trigger and hold it to the rear. The hammer falls.</p>	<p>The bolt does not lock forward.</p> <p>The hammer falls.</p> <p>The hammer does not fall.</p>

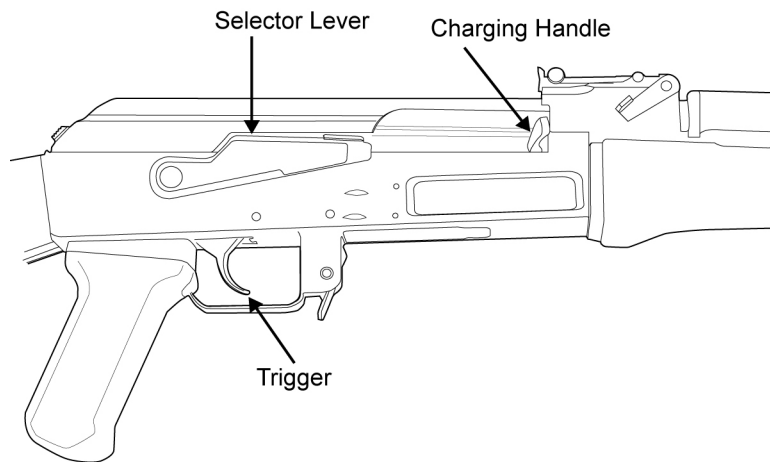


Figure 2. Charging Handle, Trigger, and Selector Lever (Selector Lever on SAFE).

Table 1. Preventive Maintenance Checks and Services for the AK-47 Rifle - Continued.

Item No.	Interval	Location of Item to Check/Service	Procedure	Not Fully Mission Capable if:
2 Cont.	Quarterly	Selector Lever -AUTO	With the hammer in the forward position, using moderate finger/thumb pressure, attempt to place the selector lever on the SAFE position. Refer to Figure 4.	Moderate finger/thumb pressure does NOT move the selector lever to the SAFE position.

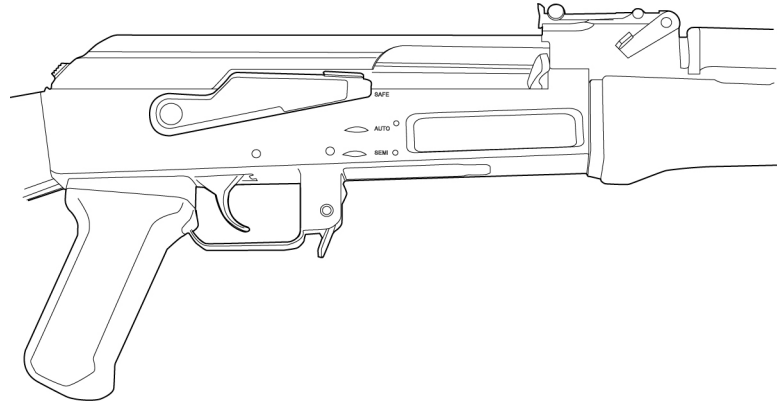


Figure 4. Selector Lever on SAFE.

3	Quarterly	Receiver Assembly	<ol style="list-style-type: none"> a. Apply a light coat of CLP to all metal parts. Remove any rust, dirt, or debris. Remove any burrs. Lubricate all moving parts. Remove excess lubricant. Refer to WP 0009 00. b. Hand check the thread protector for looseness on the barrel, then hand check the barrel for looseness on the receiver. Refer to Figure 5. 	The thread protector or barrel is loose.
---	-----------	-------------------	--	--

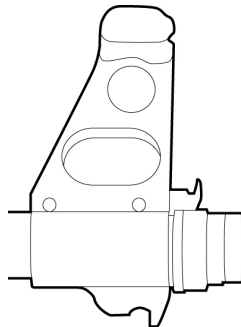


Figure 5. Thread Protector.

Table 1. Preventive Maintenance Checks and Services for the AK-47 Rifle - Continued.

Item No.	Interval	Location of Item to Check/Service	Procedure	Not Fully Mission Capable if:
3 Cont.	Quarterly	Receiver Assembly	<p>c. Remove the lower handguard and the upper handguard and gas tube. Refer to TM 8370-50007-OR/1. Inspect the handguards internally and externally for cracks and damage. Refer to Figure 6.</p> <p>d. Cracks are acceptable providing they do not extend into the front or rear of the handguards or adversely affect the weapon's operation, operator safety, or proper retention of the handguard. Refer to Figure 6.</p> <p>e. Check the gas tube for deformities or holes. Remove carbon deposits or debris. Refer to Figure 6.</p>	<p>The handguards are missing or defective.</p> <p>The gas tube has deformities, holes, carbon deposits, or debris.</p>

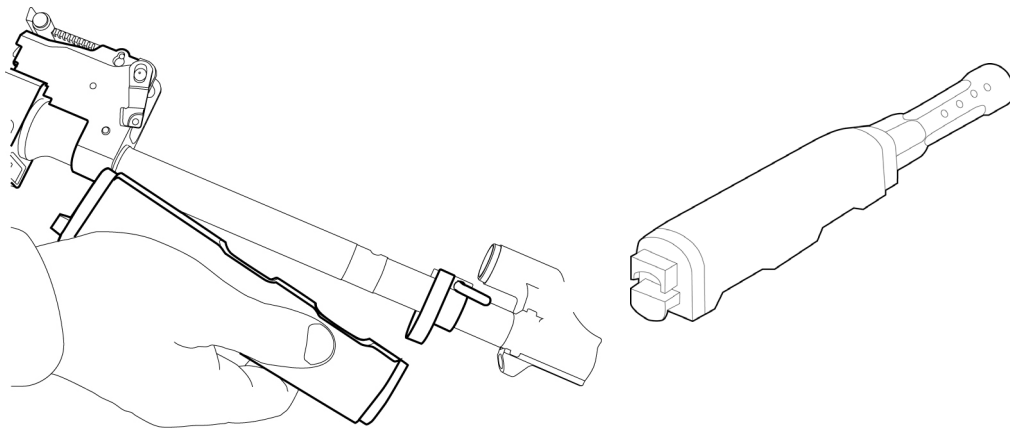


Figure 6. Lower Handguard and Upper Handguard and Gas Tube.

			<p>f. Check the gas selector, gas block, and rear sight assembly for damage and functionality.</p>	<p>The gas selector, gas block, or rear sight assembly is unserviceable or damaged.</p>
--	--	--	--	---

Table 1. Preventive Maintenance Checks and Services for the AK-47 Rifle - Continued.

Item No.	Interval	Location or Item to Check/Service	Procedure	Not Fully Mission Capable if:
3 Cont.	Quarterly	Receiver Assembly	<p>g. Inspect the pistol grip screw and pistol grip for defects or looseness on the receiver.</p> <p>h. Check the magazine release for magazine retention.</p> <p>i. Check the fixed buttstock (if present) for defects. A total of three cracks are acceptable. However, cracks near critical areas (near pins or screws) are not acceptable. Refer to Figure 7.</p>	<p>The pistol grip is defective or loose.</p> <p>The magazine release will not retain a magazine.</p> <p>The fixed buttstock has more than three cracks or any cracks near critical areas.</p>
<p>Figure 7. Fixed Buttstock.</p>				
			<p>j. Check the fixed buttstock (if present) for looseness on the receiver. If it is loose, remove the screws, clean the threads, apply thread-locker, and reinstall the screws. If necessary, replace the buttstock screws or buttstock.</p> <p>k. Check the folding buttstock (if present) for cracks and bends. Ensure it will fold and extend. Ensure it will lock in both positions. Lubricate all joints and moving parts.</p>	<p>The fixed buttstock is loose.</p> <p>The folding buttstock is damaged, will not fold and extend, or lock in both positions.</p>

Table 1. Preventive Maintenance Checks and Services for the AK-47 Rifle - Continued.

Item No.	Interval	Location or Item to Check/Service	Procedure	Not Fully Mission Capable if:
3 Cont.	Quarterly	Receiver Assembly	<p>i. Raise and lower the rear sight assembly. The rear sight leaf spring should retain the rear sight assembly in both positions with firmness.</p> <p>m. Check the front sight base, post, locking detent, and detent spring for damage or corrosion. Clean and lubricate the parts. Refer to Figure 8.</p> <p style="text-align: center;">NOTE</p> <p>If the front or rear sight is moved, return it to its original position.</p> <p>n. Check the sling swivel that is located on the left side of the gas block for damage and proper function.</p>	<p>The rear sight leaf spring will not retain the rear sight assembly in either position</p> <p>The front sight base, post, locking detent, or detent spring are damaged or corroded.</p> <p>The sling swivel is defective.</p>

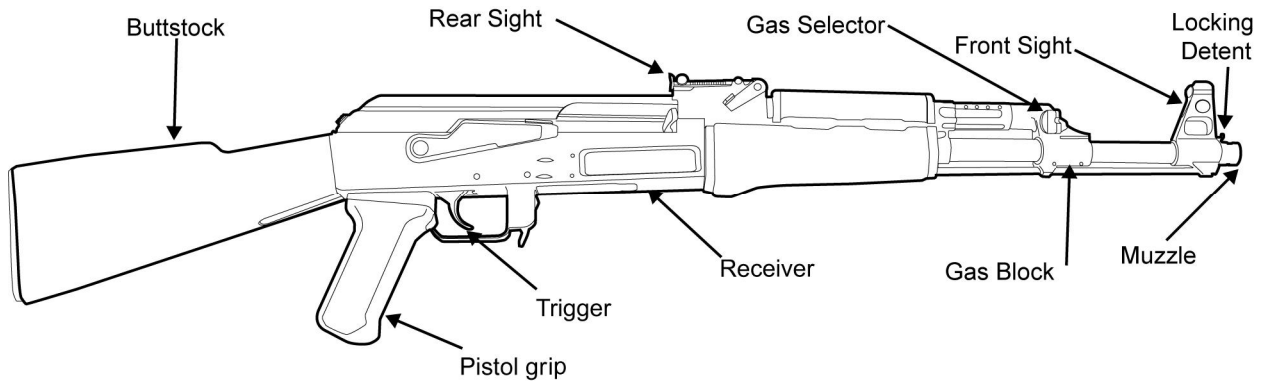


Figure 8. Receiver Assembly and Components.

Table 1. Preventive Maintenance Checks and Services for the AK-47 Rifle - Continued.




Item No.	Interval	Location or Item to Check/Service	Procedure	Not Fully Mission Capable if:
3 Cont.	Quarterly	Receiver Assembly	<div style="display: flex; justify-content: space-around; align-items: center;">   <div style="text-align: center;"> <p>WARNINGS</p> <p>Dry cleaning solvent is flammable and toxic and should be used in a well-ventilated area. The use of rubber gloves is necessary to protect the skin when washing weapon parts. Failure to follow this warning may cause injury or death to personnel.</p> <p style="text-align: center;"><u>CAUTION</u></p> <p>DO NOT use a wire brush to roughen the surfaces. Use a well-ventilated area during cleaning and the application of solid film lubricant (SFL). If SFL comes in contact with moving parts or functioning surfaces of the weapon, remove the SFL immediately by washing the area with dry cleaning solvent.</p> <p style="text-align: center;"><u>NOTE</u></p> <p>Shiny metal exterior surfaces of the weapon should be recoated with SFL. Clean the surface with dry cleaning solvent, dry, roughen with abrasive cloth, and apply solid film lubricant.</p> <ul style="list-style-type: none"> <li data-bbox="651 1270 1068 1331">o. Inspect the receiver finish for scratches or worn, shiny spots. <li data-bbox="651 1356 1101 1503">p. If scratched or worn shiny spots are present, disassemble the receiver assembly and remove all lubricant from the surface with dry cleaning solvent. <li data-bbox="651 1518 1089 1755">q. Wear chemical and oil protective gloves and use a wash pan (tote box) to apply the solvent. Let the parts dry thoroughly. Roughen the surface using abrasive cloth and apply SFL. Allow 16 to 24 hours drying time before handling. </div>  </div>	

Table 1. Preventive Maintenance Checks and Services for the AK-47 Rifle - Continued.


Item No.	Interval	Location or Item to Check/Service	Procedure	Not Fully Mission Capable if:
4	Quarterly	Bolt Carrier Assembly	<div style="text-align: center;">  <p>WARNING</p> <p>During general maintenance, DO NOT interchange bolt assemblies from one weapon to another without checking for the proper headspace. Refer to WP 0021 00. Failure to follow this warning may cause injury or death to personnel.</p> </div> <ol style="list-style-type: none"> a. Disassemble (WP 0011 00 and WP 0012 00) and inspect the bolt carrier assembly and bolt assembly for defects. Refer to Figure 8. b. Check the bolt for an elongated or cracked firing pin hole. If the firing pin hole is elongated or cracked, replace the bolt. Refer to Figure 8. c. Check for a broken or missing firing pin retaining pin. Replace the pin if necessary. Refer to Figure 8. d. Check the cartridge extractor and extractor spring for defects and serviceability. If the cartridge extractor or extractor spring are dirty, clean, lubricate, and assemble them. Replace them as necessary. Refer to Figure 8. e. Check the bolt carrier assembly (bolt carrier and gas piston) for defects. Replace the bolt carrier if necessary. Refer to Figure 8. 	<p>The bolt carrier assembly or bolt assembly are defective.</p> <p>The firing pin hole is elongated or cracked.</p> <p>There is a missing or broken firing pin retaining pin.</p> <p>The parts are missing or unserviceable.</p> <p>The bolt carrier assembly is damaged.</p>

Table 1. Preventive Maintenance Checks and Services for the AK-47 Rifle - Continued.

Item No.	Interval	Location or Item to Check/Service	Procedure	Not Fully Mission Capable if:
4 Cont.		Bolt Carrier Assembly and Bolt Assembly	f. Check the firing pin for defects. If the firing pin is damaged, replace it. Refer to Figure 9.	The firing pin is damaged.

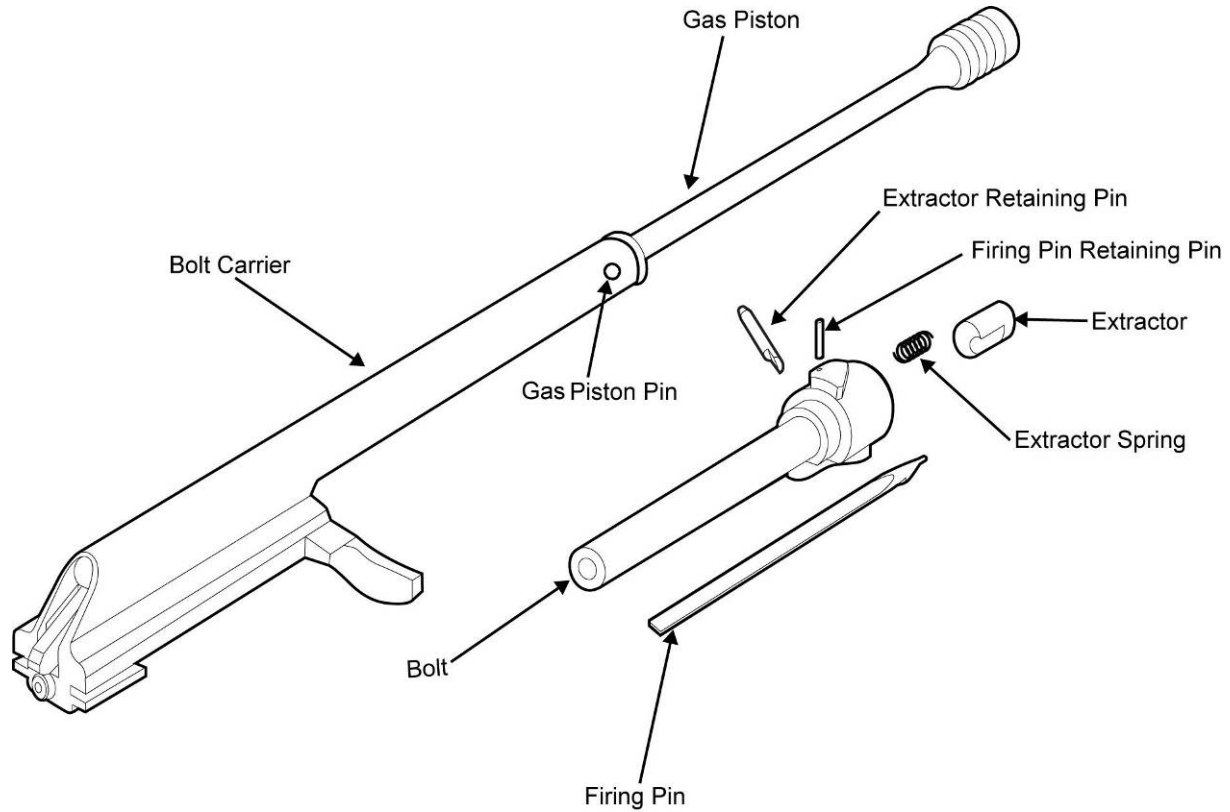
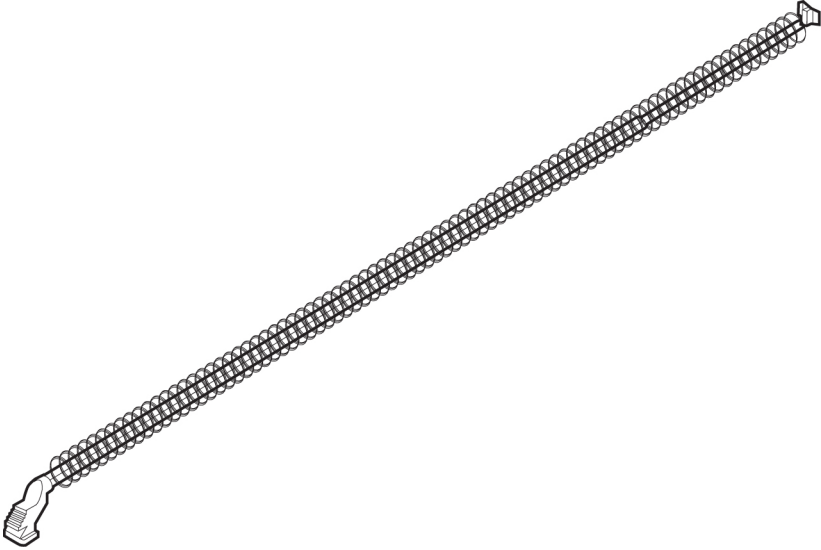
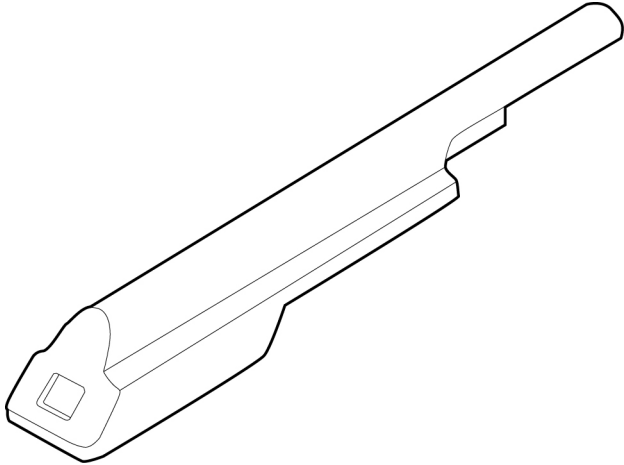


Figure 9. Bolt Carrier Assembly and Bolt Assembly Components.

Table 1. Preventive Maintenance Checks and Services for the AK-47 Rifle - Continued.

Item No.	Interval	Location or Item to Check/Service	Procedure	Not Fully Mission Capable if:
5	Quarterly	Recoil Spring and Guide Rod Assembly	Check the recoil spring and guide rod assembly for straightness, spring tension, and defects. Replace if necessary. Refer to Figure 10.	The recoil spring and guide rod assembly has weak spring tension, is bent, or defective.
				
<p>Figure 10. Recoil Spring and Guide Rod Assembly.</p>				
6	Quarterly	Top Cover	Check the top cover for dents. Replace the top cover if dented. Refer to Figure 11.	The top cover is dented.
				
<p>Figure 11. Top Cover.</p>				

INTENTIONALLY BLANK

GENERAL MAINTENANCE INSTRUCTIONS

THIS WORK PACKAGE DESCRIBES

Scope, Work Safety, General Information, Cleaning Instructions, Inspection Instructions, Repair Instructions, Lubrication Instructions, Standard Tool Requirements, Applying Torque, and Tagging Instructions.

INITIAL SETUP

Maintenance Level

Organizational

References

TM 4795-12/1_
 TM 9-247_
 WP 0008 00

SCOPE

The following general maintenance instructions contain general shop practices and specific methods used to properly maintain the AK-47 rifle.

WORK SAFETY

1. Before beginning the following tasks, ensure safety by wearing protective gear such as safety goggles or lenses, safety shoes, rubber apron, and gloves.
2. Observe all WARNINGS, CAUTIONS, and NOTES.

GENERAL INFORMATION

Before beginning a task, determine how much repair, modification, or replacement is needed to repair the weapon as described in this manual. Occasionally, the cause of equipment failure is apparent and complete disassembly of the weapon is unnecessary. Should disassembly be necessary, only disassemble the weapon so far as necessary to repair or replace the broken parts.

CLEANING INSTRUCTIONS



WARNINGS

Use only cleaner, lubricant, and preservative (CLP) for cleaning and lubrication of the AK-47 rifle in all but the most severe conditions.

Improper cleaning methods and use of unauthorized cleaning solvents may injure personnel and damage equipment. Refer to TM 9-247_, *Materials Used for Cleaning, Preserving, Abrading, and Cementing Ordnance Materials and Related Materials Including Chemicals* for correct information.

Cloths or rags saturated with solvent cleaning compound must be disposed of in accordance with authorized facilities' procedures.

WARNINGS - CONTINUED

Eye shields must be worn when cleaning with a wire brush. Flying rust and metal particles may cause injury to personnel.

Particles blown by compressed air are hazardous. Use a maximum of 30 psi when cleaning components. DO NOT exceed 15 psi nozzle pressure when drying parts with compressed air.

DO NOT direct compressed air against human skin. Make sure air stream is directed away from the user and other personnel in the area. To prevent injury, the user must wear protective goggles or a face shield.

Failure to follow these warnings may result in injury or death to personnel.

CAUTIONS

Do not mix multiple lubricants on the same weapon. The weapon must be cleaned thoroughly when changing from one lubricant to another. Dry cleaning solvent (SD) is recommended for removing the old lubricant before changing to another lubricant.

DO NOT allow CLP or any other solvent to come in contact with telescopic sight lenses or other optical devices.

NOTE

When the term lubricant or CLP is used in the following text, the lubricant used can be either CLP; lubricating oil, semi-fluid, automatic weapons (LSA); or lubricant, arctic, weapons (LAW). Cloths or rags saturated with CLP must be disposed of in accordance with authorized facilities' procedures. Cleaning instructions are the same for the majority of the parts and components of the weapon.

Maintenance personnel must thoroughly understand the importance of cleaning. Great attention to detail is required for cleaning the weapon. Dirt, dust, foreign material, and grit are a constant threat to satisfactory performance of the weapon. Thorough cleaning ensures high weapon performance. The following should apply to all cleaning, inspection, repair, and assembly operations.

1. Cleaning All Parts.

- a. Clean all parts before inspection, after repair, and before assembly.
- b. To prevent contamination, hands should be kept free of any accumulation of grease that can collect dust, dirt, or grit.
- c. After cleaning, all parts should be covered or wrapped to protect them from dust and dirt. Parts that are subject to rust should be oiled lightly.

-
2. **Cleaning Disassembled Parts.**
 - a. Dry and cover all cleaned parts.
 - b. All parts subject to rusting must be lightly oiled and wrapped.
 - c. Keep all related parts and components together. Do not interchange parts with another weapon.
 3. **Castings.**
 - a. Clean the inner and outer surfaces of castings with CLP.
 - b. Use a stiff brush to remove sludge and gum deposits.
 - c. Clear out all tapped (threaded) holes with compressed air to remove dirt and cleaning solvent.
 4. **Machined Surfaces.**
 - a. Clean machined surfaces with a pipe cleaner.
 - b. Dry surfaces thoroughly with compressed air.
 5. **Mated Surfaces.** Lightly coat with CLP and wrap all parts subject to rust before storing.

INSPECTION INSTRUCTIONS

1. **General.** Carefully check all components and parts to determine if they are serviceable for reuse, or if they must be scrapped.
2. **Drilled and Tapped (Threaded) Holes.**
 - a. Inspect for wear, distortion (stretching), cracking, or any other damage in or around holes.
 - b. Inspect threaded areas for wear, distortion, or evidence of cross-threading.
3. **Castings.**
 - a. Replace all cracked castings.
 - b. Inspect machined surfaces for nicks, burrs, or raised metal. Mark damaged areas for repair or replacement.
 - c. Inspect all screws and screw openings for damaged or stripped threads.
4. **Studs, Bolts, and Screws.** Replace if threads are damaged, bent, or stretched.
5. **Machine-Tooled Parts.** Inspect parts for cracks, breaks, elongated holes, wear, and chips. Replace any damaged parts.
6. **Machined Surfaces.** Inspect machined surfaces for cracks, evidence of wear, galled or pitted surfaces, burrs, nicks, and scratches.
7. **Mating Surfaces.** Inspect mating surfaces for proper seal, secure fit, and pitting.
8. **Rusted Surfaces.** Inspect rusted surfaces for pitting, holes, and severe damage.

9. **Internal Parts**. Inspect internal parts for cracks, nicks, burrs, evidence of overheating, and wear.
10. **Externally Exposed Parts**. Inspect externally exposed parts for breaks, cracks, rust damage, and wear.
11. **Springs**. Inspect springs for broken, collapsed, and twisted coils.

REPAIR INSTRUCTIONS

1. **General**. Any repair procedure for a specific part is covered in the working package related to that item.

CAUTION

Repaired items must be thoroughly cleaned to remove metal and abrasives to prevent them from entering working parts of the weapon.

2. **Castings**. Only minor repairs to machined surfaces are permitted (e.g. removing minor nicks, burrs, and scratches) using a fine-mill file and crocus cloth with solvent cleaning compound.

LUBRICATION INSTRUCTIONS

Refer to *Preventive Maintenance Checks and Services (PMCS)* (WP 0008 00) for detailed, illustrated instructions on proper lubrication. The following are some general practices to remember.

1. Use the correct lubricant in accordance with TM 4795-12/1_, *Organizational Corrosion Prevention and Control Procedures for USMC Equipment*.
2. Keep the lubricants clean.
3. Lubricate all clean, disassembled, and new parts to prevent rust.

STANDARD TOOL REQUIREMENTS

Some maintenance tasks may require special or fabricated tools. The initial setup of the procedure will specify any special or fabricated tools needed to perform that procedure. Special tools should be used only for the maintenance procedures for which they are designed or called out. If you are unfamiliar with a required tool, see your supervisor.

APPLYING TORQUE

If a unique torque value is required, it will be provided in a procedural step in the task.

TAGGING INSTRUCTIONS

1. Use marker tags to identify all parts that may be hard to identify or replace later. Fasten the tags to parts during removal by wrapping wire fasteners around or through the parts and twisting the ends together. Position the tags out of the way during cleaning, inspection, and repair. Mark the tags with a pencil, pen, or marker.
2. Identify and tag other parts by name and the installed location as required.

END OF WORK PACKAGE

DISASSEMBLY OF WEAPON

THIS WORK PACKAGE DESCRIBES

Disassembly.

INITIAL SETUP

Maintenance Level

Organizational

Equipment Conditions

Weapon cleared (TM 8307-50007-OR/1)

References

TM 8307-50007-OR/1



WARNING

Always assume that every weapon is loaded until it is determined through visual and physical inspection that it is not. Procedures for clearing and unloading the weapon are outlined in TM 8307-50007-OR/1. Failure to follow this warning may cause injury or death to personnel.

DISASSEMBLY

Remove the magazine, cleaning rod, handguards, top cover, recoil spring and guide rod assembly, and bolt carrier assembly and bolt assembly from the receiver.

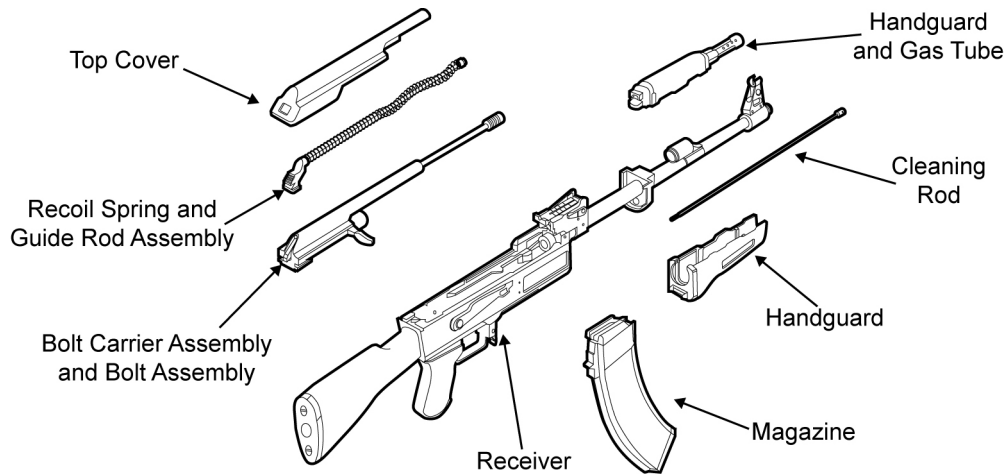


Figure 1. Major Components of the AK-47 Disassembled.

END OF WORK PACKAGE

INTENTIONALLY BLANK

BOLT CARRIER ASSEMBLY AND BOLT ASSEMBLY

THIS WORK PACKAGE DESCRIBES

Disassembly, Cleaning, Inspection and Repair, Lubrication, and Reassembly.

INITIAL SETUP**Maintenance Level**

Organizational

Tools and Special Tools

E7900 tool kit

References

TM 8370-50007-OR/1
WP 0010 00
WP 0012 00
WP 0025 00

Equipment Conditions

Bolt carrier assembly and bolt assembly removed (WP 0010 00)

**WARNING**

DO NOT interchange bolt assemblies from one weapon to another without checking for the proper headspace. Failure to follow this warning may cause injury or death to personnel.

DISASSEMBLY

1. Push the bolt assembly into the bolt carrier. Refer to Figure 1.

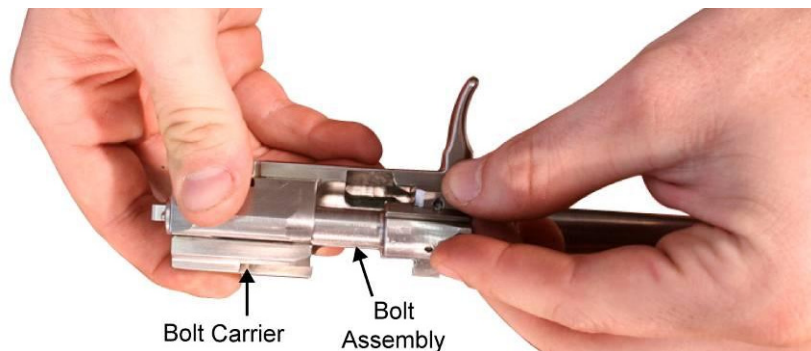


Figure 1. Pushing the Bolt Assembly into the Bolt Carrier.

2. Rotate the bolt assembly to disengage the bolt cam, located on the rounded locking lug, from the machined cam recess of the bolt carrier. Refer to Figure 2.

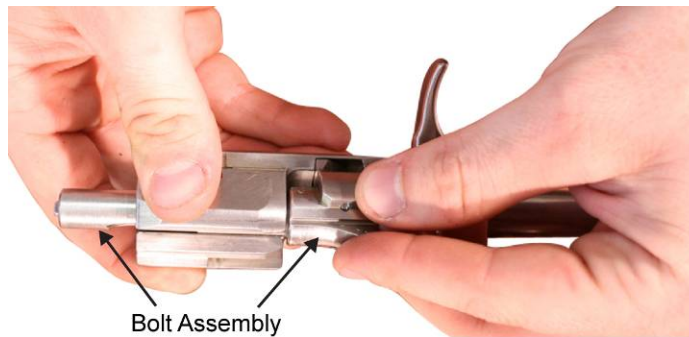


Figure 2. Disengaging the Bolt Cam from the Cam Recess.

3. Pull the bolt assembly completely out of the bolt carrier. Refer to Figure 3.

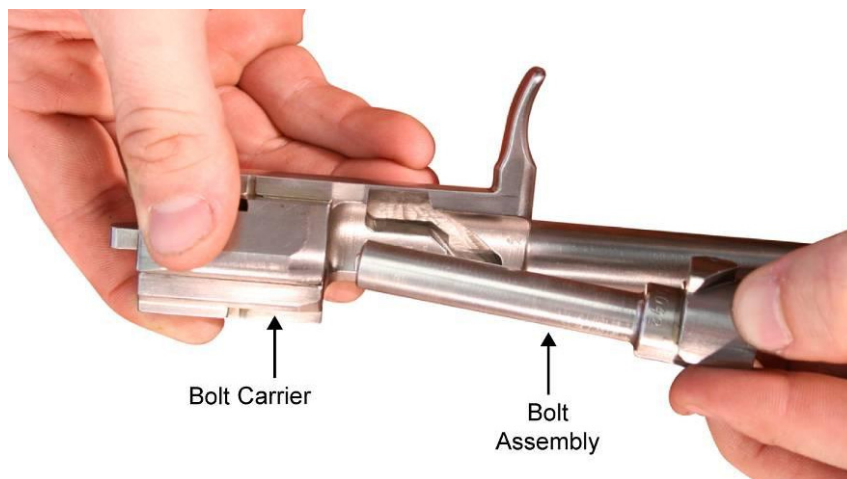


Figure 3. Pulling the Bolt Assembly Out of the Bolt Carrier.

CLEANING

Clean and remove all carbon deposits. Refer to TM 8370-50007-OR/1.

INSPECTION AND REPAIR

1. Inspect the bolt carrier assembly (bolt carrier and gas piston) as follows:
 - a. Check the bolt carrier assembly for burrs, cracks, deformities, and defects. Remove any burrs. Replace if damaged.
 - b. Check the cam recess for burrs, cracks, deformities, and defects. Remove any burrs. Replace if damaged.
 - c. Clean, inspect, repair, and lubricate the bolt assembly. Refer to WP 0012 00.

LUBRICATION

For all lubrication requirements refer to TM 8370-50007-OR/1.

REASSEMBLY

1. Push the bolt assembly into the bolt carrier. Refer to Figure 4.

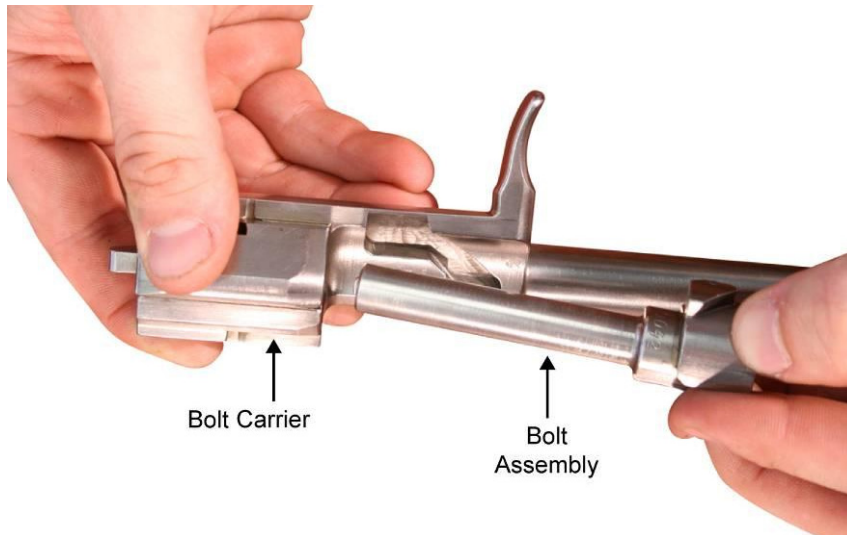


Figure 4. Pushing the Bolt Assembly into the Bolt Carrier.

2. Rotate the bolt to mate the bolt cam, located on the locking lug, with the machined cam recess of the carrier. Refer to Figure 5.

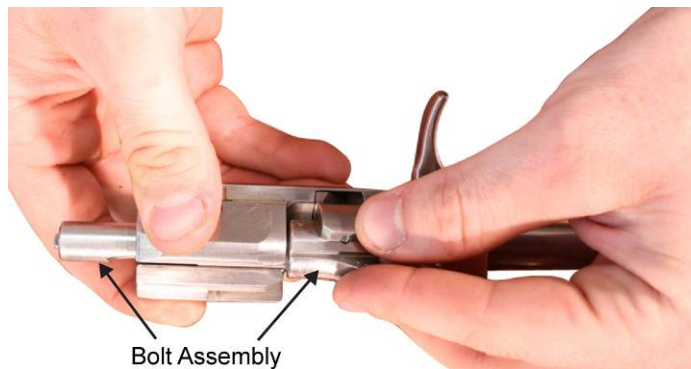


Figure 5. Mating the Bolt Cam with the Cam Recess.

3. While turning the bolt assembly, engage the bolt cam into the cam recess of the bolt carrier by pulling the bolt assembly toward the front of the bolt carrier. Refer to Figure 6.

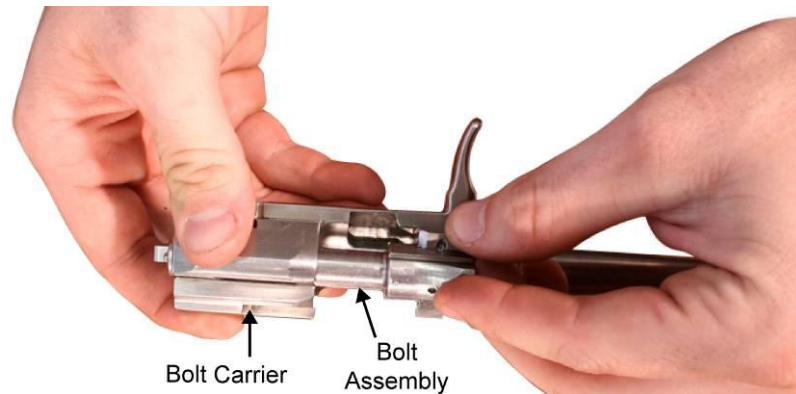


Figure 6. Engaging the Bolt Assembly with the Bolt Carrier.

NOTE

Ensure that the installed bolt assembly moves smoothly forward and rearward in the bolt carrier.

END OF WORK PACKAGE

BOLT ASSEMBLY

THIS WORK PACKAGE DESCRIBES

Disassembly, Cleaning, Inspection and Repair, Lubrication, and Reassembly.

INITIAL SETUP**Maintenance Level**

Organizational

Tools and Special Tools

E7900 tool kit
Penetrant kit

References

TM 8370-50007-OR/1
WP 0011 00
WP 0021 00
WP 0025 00

Equipment Conditions

Bolt assembly removed (WP 0011 00)

**WARNING**

DO NOT interchange bolt assemblies from one weapon to another without checking for the proper headspace. Failure to follow this warning may cause injury or death to personnel.

DISASSEMBLY

1. Using a bench block, insert a 1/16-inch punch into the firing pin retaining pin hole, on the side of the bolt opposite the cam, to push out the firing pin retaining pin. Refer to Figure 1.



Figure 1. Removing the Firing Pin Retaining Pin.

2. Remove the firing pin from the bolt. Refer to Figure 2.

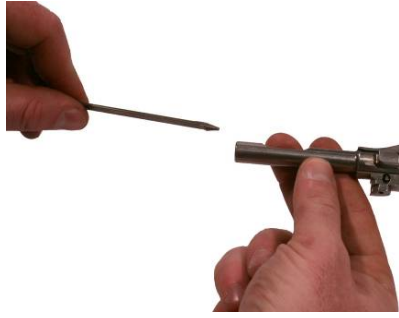


Figure 2. Removing the Firing Pin.



WARNING

The grooved extractor retaining pin and extractor are under spring tension.

3. While maintaining pressure on the extractor to relieve the spring tension, use a 1/16-inch punch to remove the grooved extractor retaining pin. Refer to Figure 3.



Figure 3. Removing the Grooved Extractor Retaining Pin.

4. Remove the extractor, and extractor spring. Refer to Figure 4.



Figure 4. Removing the Extractor and Extractor Spring.

CLEANING

Clean and remove all carbon deposits. Refer to TM 8370-50007-OR/1.

INSPECTION AND REPAIR

1. Check the firing pin retaining pin for bends and breaks. Replace the firing pin retaining pin if damaged.
2. Check the firing pin for bends and breaks. Replace the firing pin if damaged.
3. Check the extractor for burrs, chips, and cracks. Replace the extractor if damaged.
4. Check the extractor spring for spring tension, bends, or breaks. Replace the extractor spring if damaged.
5. Check the grooved extractor retaining pin for bends or breaks. Replace the grooved extractor retaining pin if damaged.
6. Inspect the bolt as follows (refer to Figure 5):

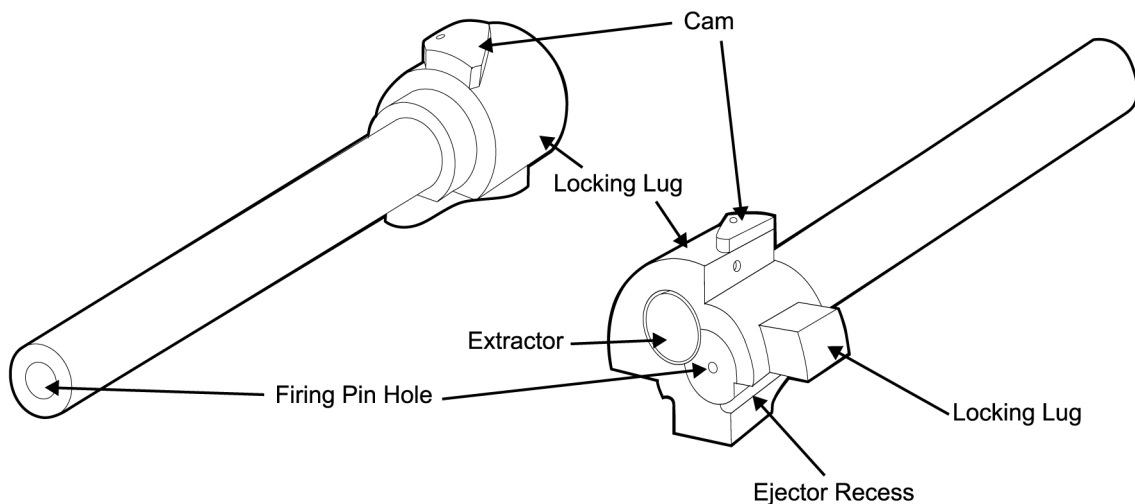


Figure 5. Opposite Views of the Bolt.

- a. Check the bolt for pits, burrs, and wear as follows:
 - (1) If the bolt face has a cluster of pits that are tightly grouped or touching and cover an area approximately 1/8-inch across or larger, reject and replace the bolt.
 - (2) The bolt can contain individual or scattered pits and not be rejected.
 - (3) If the bolt face contains pits that extend into the firing pin hole, gage the bolt with the plain plug “no go” gage. Refer to WP 0021 00. Replace if defective.
 - (4) Machine tool marks (rings, grooves, or ridges) on the bolt face less than approximately 0.010-inch are acceptable.
- b. Check for cracks in the bolt. Use the penetrant kit to check for cracks in the bolt as follows:
 - (1) Clean the area to be inspected to ensure that it is free of dirt, grit, and grease by spraying a small amount of remover on the area to be inspected. Let it dry, and then wipe the area off with a rag.

- (2) Spray penetrant (enough to wet the area) on the area of the bolt to be inspected.
- (3) Spray developer over the area covered in penetrant, and let it sit for five to ten seconds. A crack will be indicated by a change in color where the crack is located. If cracks appear, the component is unserviceable and must be replaced.
- (4) Pay close attention to the area where the locking lugs meet the body.
- (5) If there are no cracks, spray remover on the area covered in developer, let it dry, and then wipe it with a rag.
- (6) Oil the area to prevent corrosion.

**WARNING**

If the bolt is replaced, perform head space gaging. Refer to WP 0021 00.

- (7) Replace the bolt if damaged.

LUBRICATION

For all lubrication requirements, refer to TM 8370-50007-OR/1.

REASSEMBLY

1. Install the extractor spring into the extractor and install them into the bolt. Refer to Figure 6.

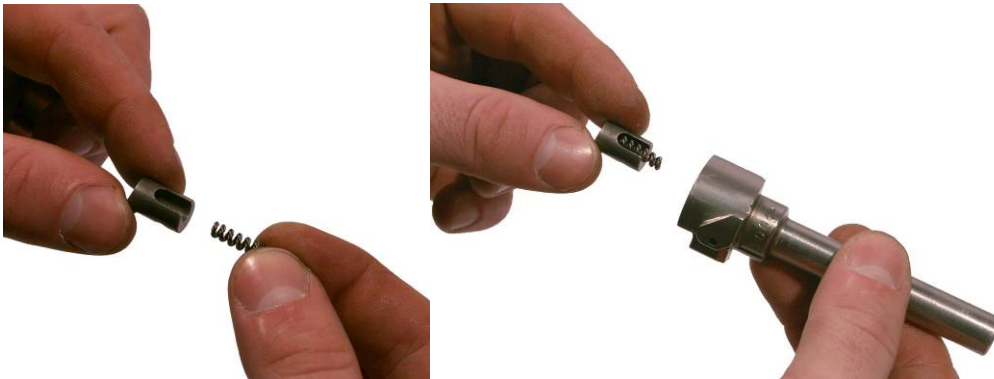


Figure 6. Installing Extractor and Extractor Spring.

CAUTION

Ensure the groove in the grooved extractor retaining pin is aligned with the firing pin retaining pin hole BEFORE inserting the firing pin retaining pin. Failure to do so may cause the firing pin retaining pin to lodge in the bolt permanently.

2. Maintaining pressure on the extractor to relieve spring tension, insert a 1/16-inch punch into the SMALL side of the extractor retaining pin hole in order to align the slot in the extractor with the grooved extractor retaining pin hole. Install the grooved extractor retaining pin into the LARGE side of the grooved extractor retaining pin hole (next to the bolt cam). Ensure that the grooved side of the pin is on the LARGE side of the pin hole. Ensure it is at least flush. Refer to Figure 7.



Figure 7. Installing the Grooved Extractor Retaining Pin.

3. Install the firing pin into the bolt. Ensure the flat side of the firing pin is facing the small, squared locking lug. Refer to Figure 8.

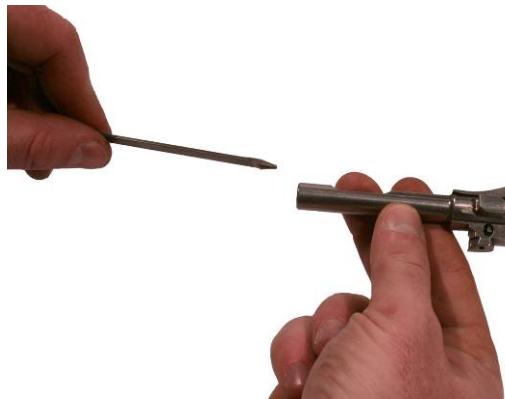


Figure 8. Installing the Firing Pin.

-
- Align the groove in the end of the grooved extractor retaining pin with the firing pin retaining pin hole.

NOTE

The firing pin may turn while installing the firing pin retaining pin. Ensure that the flat side of the firing pin is facing the small, squared locking lug.

- Using a hammer, lightly tap in the firing pin retaining pin until it is flush. Refer to Figure 9.

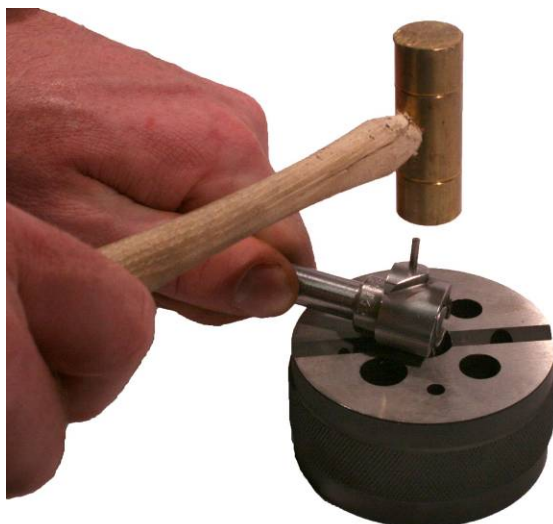


Figure 9. Installing the Firing Pin Retaining Pin.

END OF WORK PACKAGE

RECEIVER ASSEMBLY

THIS WORK PACKAGE DESCRIBES

Disassembly, Cleaning, Inspection and Repair, Lubrication, and Reassembly.

INITIAL SETUP**Maintenance Level**

Organizational

References

WP 0009 00

WP 0010 00

WP 0011 00

WP 0014 00

WP 0015 00

WP 0022 00

WP 0025 00

TM 8370-50007-OR/1.

Tools and Special Tools

E7900 tool kit

Front sight adjustment tool

Combination tool

Equipment Conditions

Weapon field stripped (WP 0010 00)

DISASSEMBLY**1. Muzzle and Front Sight.**

- a. Remove the thread protector from the muzzle of the barrel by holding down the locking detent with a punch and unscrewing the thread protector until it comes off. Refer to Figure 1.

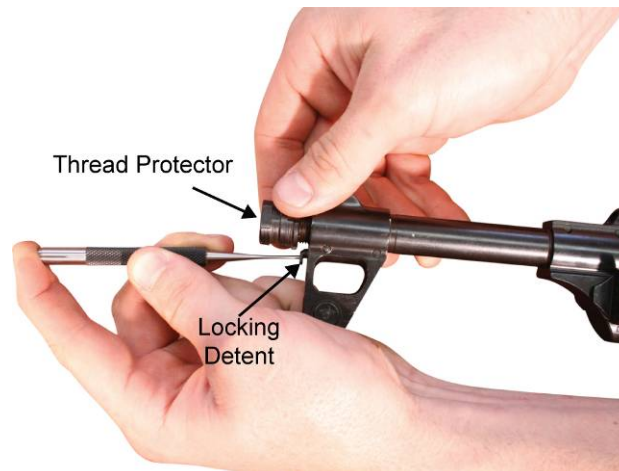


Figure 1. Depressing the Locking Detent and Removing the Thread Protector.

NOTE

The M249 front sight tool can also be used for working on the front sight.

- b. Use the front sight adjustment tool or the combination tool (refer to Figure 2) to remove the front sight post. Refer to Figure 3.



Figure 2. Front Sight Adjustment Tool (left) and Combination Tool (right).

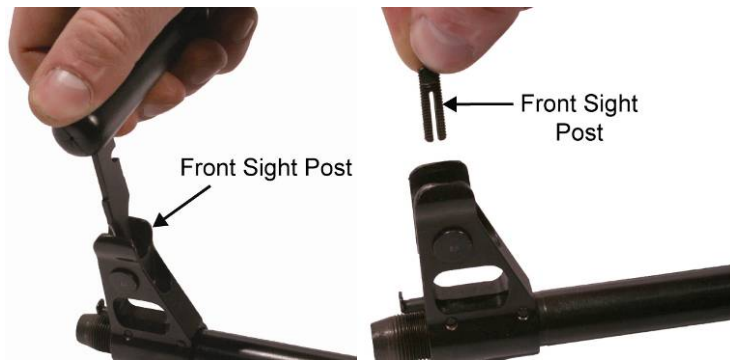


Figure 3. Removing the Front Sight Post.

- c. Use the front sight adjustment tool to remove the windage drum. Place the ends of the clamp on either side of the windage drum and turn the handle to push the drum out of the front sight base and through the hole in the front sight adjustment tool. Refer to Figure 4.

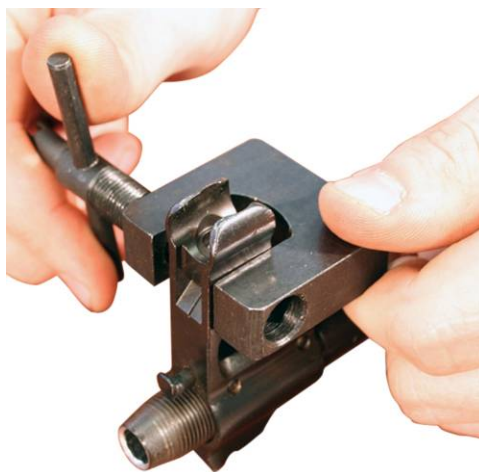


Figure 4. Removing the Windage Drum.

2. Gas Block.

- a. The gas selector must be in the UP position, indicating normal use. Refer to Figure 5.

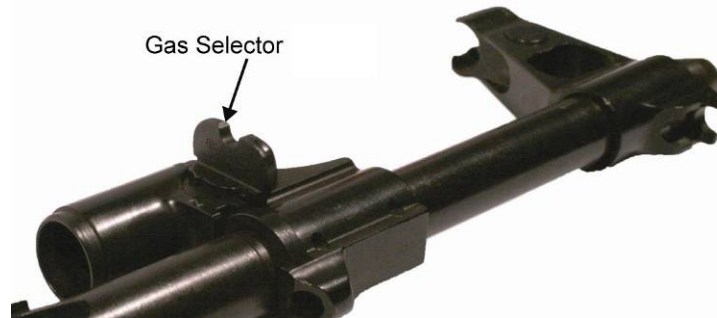


Figure 5. Gas Selector in the UP Position.

CAUTION

The C-clip can break or deform during removal. If the C-clip becomes broken or deformed, replace the C-clip.

- b. Remove the C-clip located on the left side of the gas block by using the scraper tool and pulling away from the open end of the C-clip. Refer to Figure 6.



Figure 6. Removing the C-Clip with the Scraper Tool.

- c. Remove the gas collar located on the left side of the gas block. Refer to Figure 7.



Figure 7. Removing the Gas Collar.

- d. Pull the gas selector out from the right side of the gas block. Refer to Figure 8.



Figure 8. Removing the Gas Selector.

3. Rear Sight.

- a. Extend the rear sight. Refer to Figure 9.

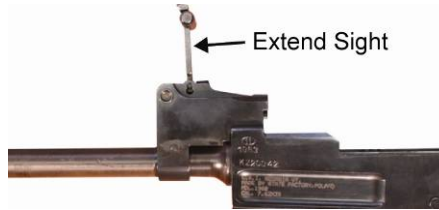


Figure 9. The Rear Sight Extended.

- b. While pulling the bottom of the rear sight assembly rearward, use a dead blow mallet to tap on the top of the rear sight assembly to dislodge it. Refer to Figure 10.



Figure 10. Dislodging and Removing the Rear Sight Assembly Using a Dead Blow Mallet.

NOTE

As an alternative to steps a and b, follow step c to remove the rear sight assembly.

- c. Tilt the rear sight assembly to a 45 degree angle. While pressing down and forward on the narrow end of the rear sight leaf spring with a punch or flat head screw driver, hold the rear sight assembly with fingers and press down firmly to remove the rear sight assembly studs from the holes in the rear sight base. Refer to Figure 11.

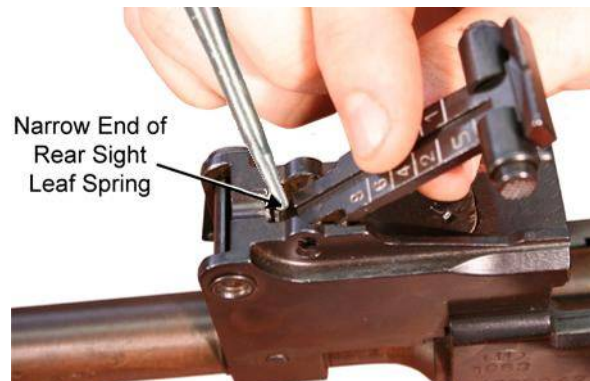


Figure 11. Dislodging the Rear Sight Assembly for Removal.

- d. When the rear sight assembly dislodges from the track of the rear sight base, pull it to the rear to remove it.

NOTE

The rear sight leaf spring is staked into the rear sight base.

- e. To remove the rear sight leaf spring, pull up at a 45 degree angle on the narrow, forward end with needle-nosed pliers. Refer to Figure 12.



Figure 12. Removing the Rear Sight Leaf Spring.

4. **Trigger Assembly.**



WARNING

The auto sear is under spring tension. Use care when removing or installing the auto sear.

NOTE

The long leg of the auto sear spring is set into the grooves in the heads of the three retaining pins in the receiver in order to retain the pins in the receiver. The auto sear spring must be lifted or lowered out of the grooves in the pins before the pins can be removed. Refer to Figure 13.

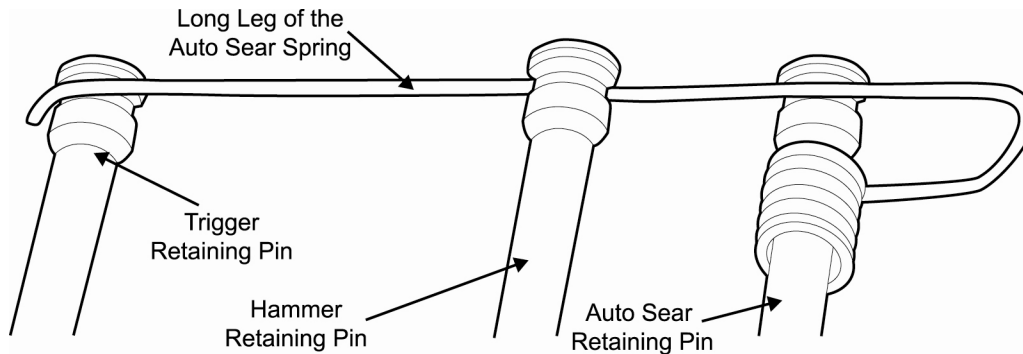


Figure 13. Proper Installation of the Auto Sear Spring.

- a. Use a punch or the scraper tool to lift the long leg of the auto sear spring out of the groove in the head of the trigger retaining pin. Refer to Figure 14.



Figure 14. Removing the Long Leg of the Auto Sear Spring from the Groove in the Trigger Retaining Pin.

WARNING

After pushing down the arm of the auto sear, the hammer will be under spring tension. Pulling the trigger will release the hammer and it will fall forward with force.

CAUTION

Letting the hammer fall uncontrolled will damage the weapon. Ensure to place a finger over the hammer before pulling the trigger in order to ride the hammer forward.

- b. Using a punch, push the arm of the auto sear, against the right wall of the receiver, forward until an audible click is heard. Using a finger to ride the hammer forward, pull the trigger to release the spring tension on the hammer. Refer to Figure 15.

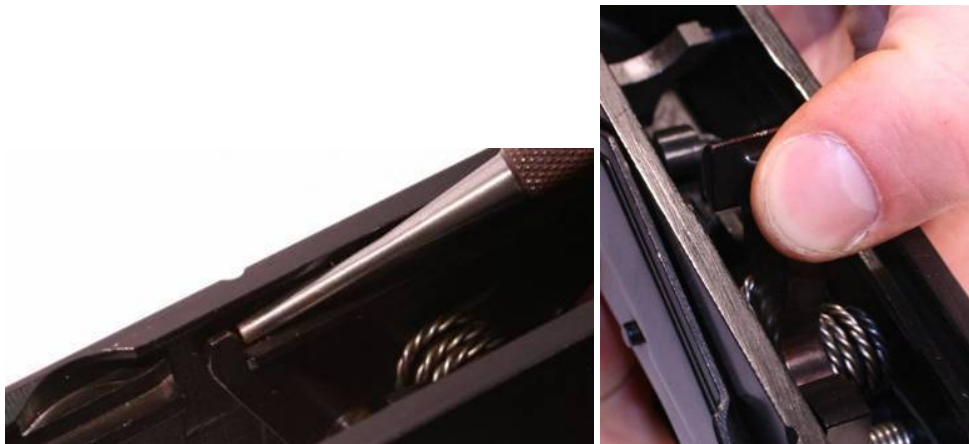


Figure 15. Depressing the Arm of the Auto Sear and Riding the Hammer Forward.

CAUTION

Only moderate pressure is necessary to remove the retaining pins from the receiver. If a retaining pin is difficult to remove, check to ensure that the groove in the head the retaining pin is not caught on the receiver wall.

- c. Use a punch to push the trigger retaining pin from the right side of the receiver and remove the pin from the left side of the receiver. Refer to Figure 16.



Figure 16. Using a Punch to Push Out the Trigger Retaining Pin.

- d. Remove the disconnecter and disconnecter spring. (If present, remove the interrupter and interrupter spring.) Refer to Figure 17.

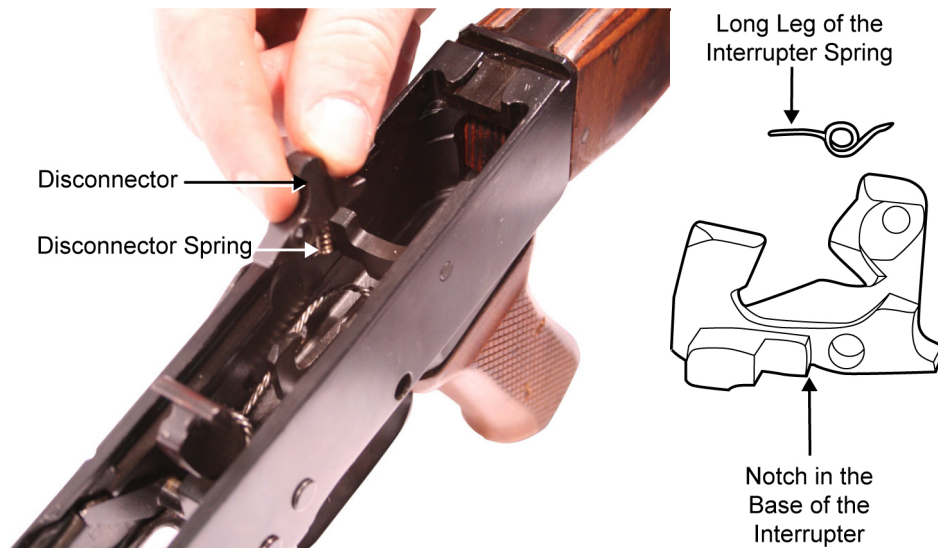


Figure 17. Removing the Disconnecter and Disconnecter Spring.

- e. Remove the disconnecter spring from the disconnecter. Refer to Figure 18.



Figure 18. Removing the Disconnecter Spring from the Disconnecter.

- f. Rotate the selector lever up to the 12 o'clock position and pull it out of the right side of the receiver. Refer to Figure 19.



Figure 19. Rotating and Removing the Selector Lever.



WARNING

The hammer spring is under spring tension and the ends may be sharp enough to puncture the skin.

- g. Using needle-nosed pliers or the curved scraper tool, pull the ends of the hammer spring behind the hammer. If necessary, secure the ends with wire. Refer to Figure 20.

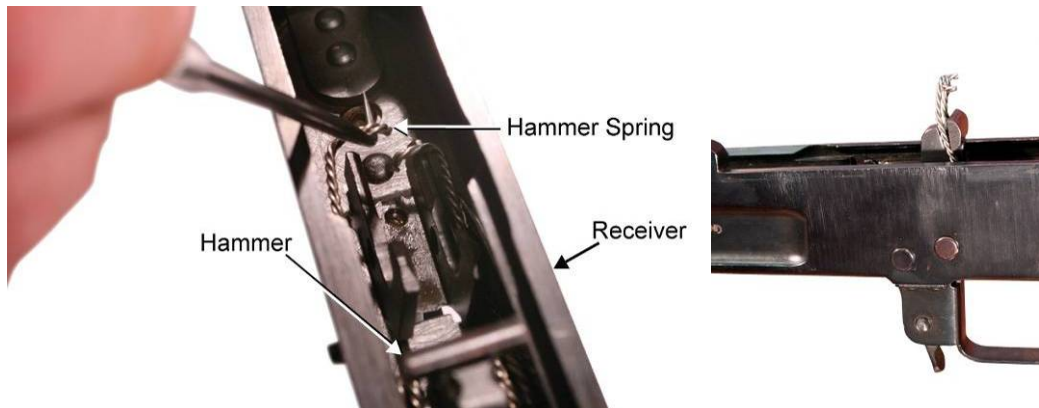


Figure 20. Placing the Ends of the Hammer Spring Behind the Hammer.

- h. Remove the trigger. Refer to Figure 21.



Figure 21. Removing the Trigger.

CAUTION

Only moderate pressure is necessary to remove the retaining pins from the receiver. If a retaining pin is difficult to remove, check to ensure that the groove in the head the retaining pin is not caught on the receiver wall.

- i. Using a punch or flat head screwdriver, apply downward pressure on the auto sear spring to push the long leg of the auto sear spring out of the retaining groove in the hammer retaining pin. Using a punch, push the hammer pin from the right side of the receiver and remove the pin from the left side of the receiver. Refer to Figure 22.

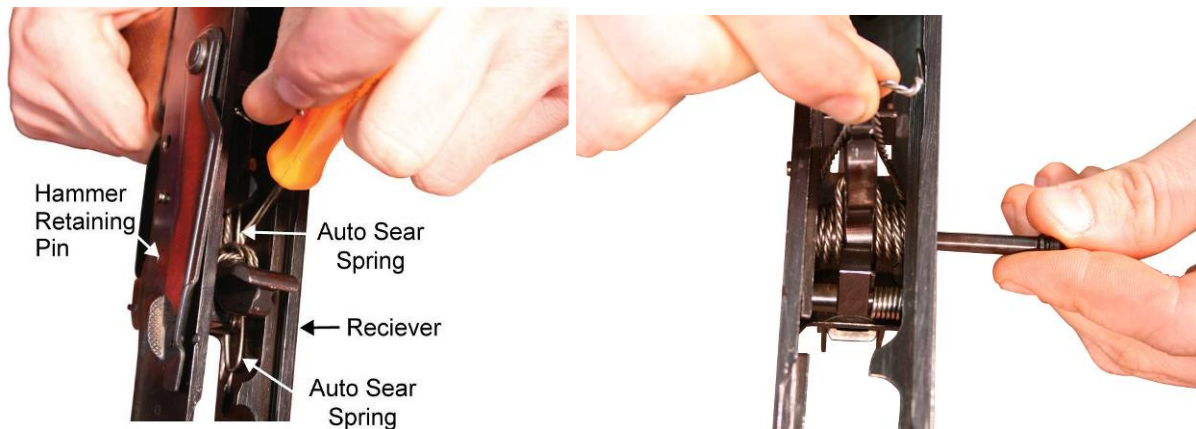


Figure 22. Pushing the Long Leg of Auto Sear Spring out of the Groove in the Hammer Retaining Pin and Removing the Hammer Retaining Pin.

- j. Rotate the hammer and hammer spring 90° as an assembly, and lift it out of the receiver. If the hammer is difficult to remove, move it to the rear of the receiver, past the rails in the receiver, and then remove it from the receiver. Refer to Figure 23.



Figure 23. The Hammer and Hammer Spring Removed.

- k. Pull the long leg of the auto sear spring out of the groove in the auto sear retaining pin.

CAUTION

Only moderate pressure is necessary to remove the retaining pins from the receiver. If the retaining pins are difficult to remove, check to ensure that the grooves near the end of the retaining pins are not caught on the receiver wall.

- l. Maintaining pressure on the auto sear spring, use a punch to push the auto sear retaining pin from the right side of the receiver and remove the pin from the left side of the receiver. Refer to Figure 24.

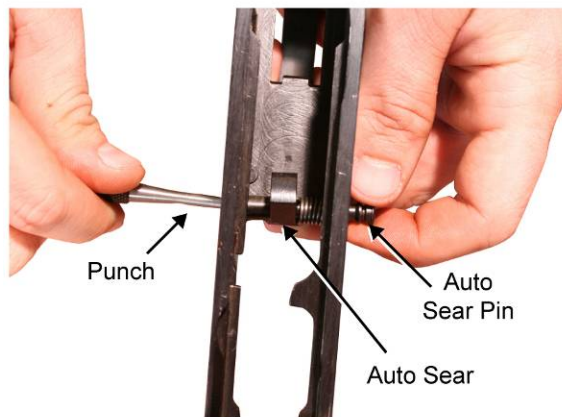


Figure 24. Removing the Auto Sear Retaining Pin.

- m. Remove the auto sear and auto sear spring from the receiver. Refer to Figure 25.

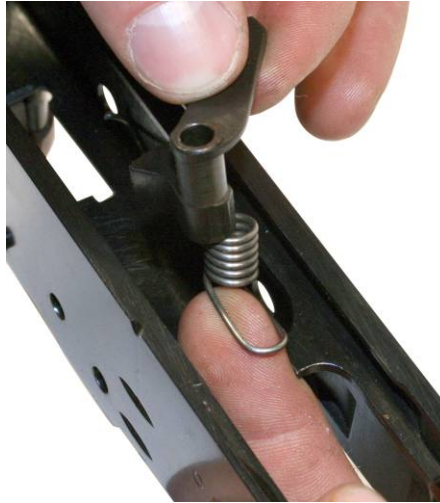


Figure 25. Removing the Auto Sear and Auto Sear Spring from the Receiver.

- n. Remove the auto sear spring from the auto sear. Refer to Figure 26.

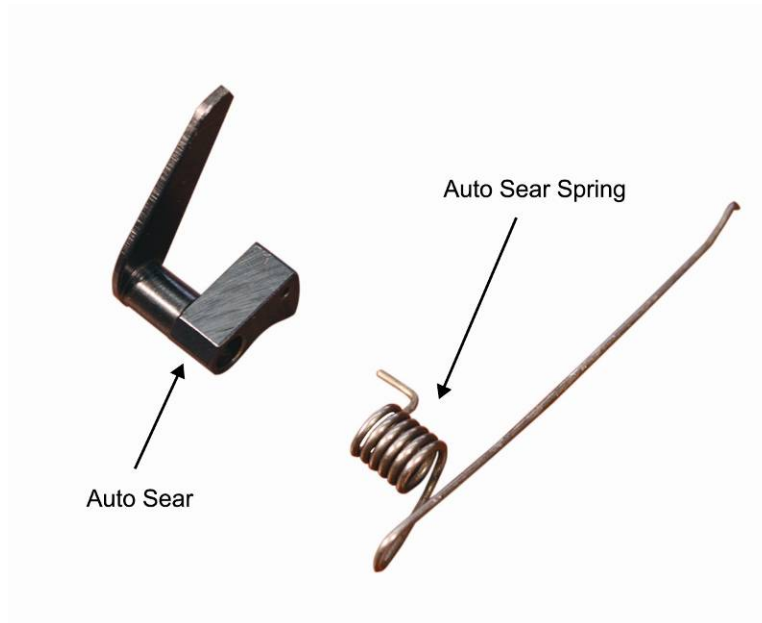


Figure 26. The Auto Sear Spring Removed from the Auto Sear.

5. Pistol Grip.

- a. Using a flat head screwdriver, remove the pistol grip screw from the bottom of the pistol grip. Refer to Figure 27.



Figure 27. Removing the Pistol Grip Screw.

NOTE

The pistol grip block, if present, is removed through the top of the receiver.

- b. Remove the pistol grip and pistol grip screw mounting block (if present) from the weapon.
6. **Fixed Buttstock.** Using a flat head screwdriver, remove the top buttstock screw and the two bottom buttstock screws located at the front of the fixed buttstock near the receiver. Pull the fixed buttstock to the rear and remove the fixed buttstock from the receiver. Refer to Figure 28.



Figure 28. Removing Buttstock Screws and Pulling the Fixed Buttstock from the Receiver.

CLEANING

Clean and remove all carbon deposits from the weapon. Refer to TM 8370-50007-OR/1.

INSPECTION AND REPAIR

1. Muzzle, Front Sight, and Gas Block.

- a. Check the front sight post and windage drum for cracks, bends, or distortion. Replace the front sight post or windage drum if damaged.
- b. Check the front sight base for cracks, bends, or breaks. Replace the front sight base if damaged.
- c. Check the gas block for cracks, bends, or breaks. Replace the gas block if damaged.
- d. Check the locking detent spring for breaks or bends. Replace the spring if damaged.

-
- e. Check the locking detent for burrs, bends, or breaks. Remove the burrs. Replace the locking post if damaged.
 - f. Check the C-clip for bends, breaks, or deformities. Replace the C-clip if damaged.
 - g. Check the bayonet lug, located under front sight, for proper fit of bayonet. Check for burrs. Remove any burrs.

2. **Receiver Assembly.**

- a. Check the receiver for cracks, burrs, or deformities. Remove any burrs. Replace if damaged.
- b. Check the barrel for looseness in the receiver. Attempt to repair if loose. If beyond repair, replace the receiver.
- c. Check the ejector for cracks, burrs, or deformities. Remove any burrs. Attempt to repair if deformed. If beyond repair, replace the receiver. If the ejector is worn so that it will no longer eject cartridges during firing, replace the receiver.
- d. Check the magazine release for spring tension. If there is no spring tension, attempt to repair.

3. **Rear Sight.**

- a. Check the rear sight leaf spring for breaks or deformities. Replace the rear sight leaf spring if damaged
- b. Disassemble, clean, lubricate, repair, and reassemble the rear sight assembly. Refer to WP 0014 00.

4. **Trigger Assembly.**

- a. Check all trigger components for excessive wear, burrs, bends, breaks, and cracks. Remove any burrs and replace the components if damaged.
- b. Check all springs for bends, breaks, flat spots, and spring tension. Replace the springs if damaged.

5. Fixed Buttstock.

- a. Check the fixed buttstock for cracks. Up to three cracks are acceptable. No cracks are acceptable in the critical areas (near pins or screws). Refer to Figure 29. Replace the buttstock if damaged.

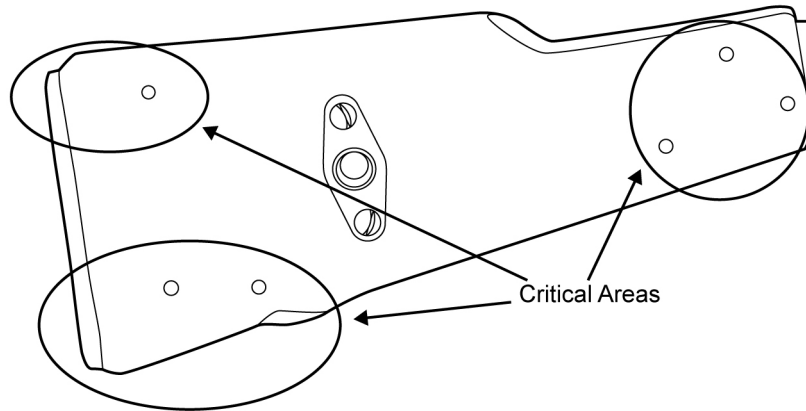


Figure 29. Critical Areas of the Fixed Buttstock.

- b. Check the buttstock screws for burrs. Remove the burrs. Replace the screws if damaged.
- c. Disassemble, clean, lubricate, repair, and reassemble the buttplate and trap door. Refer to WP 0015 00.

LUBRICATE

Lubricate all metal parts with CLP. Refer to WP 0009 00.

REASSEMBLY

1. Fixed Buttstock.

- a. Align the fixed buttstock with the rear of the receiver. Install and secure it with the one, shorter top buttstock screw and the two, longer bottom buttstock screws. Refer to Figure 30.



Figure 30. Aligning and Installing the Fixed Buttstock onto the Rear of the Receiver.

2. Pistol Grip.

- a. Install the pistol grip screw mounting block, if present, through the top of the receiver. Install the pistol grip. Using a flat head screw driver, install the pistol grip screw through the pistol grip and into the mounting block. Refer to Figure 31.



Figure 31. Installing the Pistol Grip.

- b. Ensure the pistol grip is secure.

3. Trigger Assembly.

NOTE

When installing the retaining pins, ensure that the long leg of the auto sear spring is properly installed. Refer to Figure 32. The long leg of the auto sear spring must be properly set into the grooves in the heads of the three retaining pins in the receiver in order to retain the pins in the receiver.

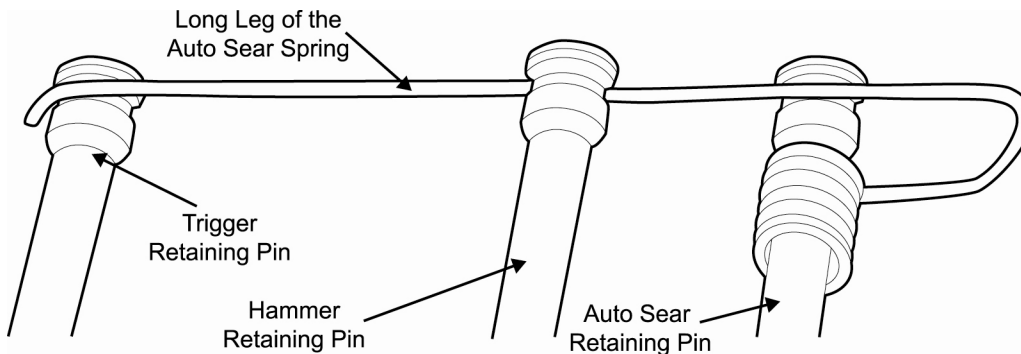


Figure 32. Proper Installation of the Long Leg of the Auto Sear Spring.

- a. Install the short leg of the auto sear spring in the auto sear. Refer to Figure 33.



Figure 33. The Short Leg of the Auto Sear Spring Installed in the Auto Sear.

NOTE

When installing the auto sear and auto sear spring, use a punch, inserted from the right side of the receiver, as a slave pin to hold them in place until the auto sear retaining pin is installed.

- b. Install the auto sear assembly in the receiver. Ensure that the arm of the auto sear is against the right side of the receiver and the long leg of the auto sear spring is against the left side of the receiver.

CAUTION

Only moderate pressure is necessary to install the retaining pins into the receiver. If the retaining pins are difficult to install, check to ensure that the grooves in the heads of the retaining pins are not caught on the receiver wall.

- c. Insert the auto sear retaining pin from the left side of the receiver, ensuring to thread the pin through the auto sear spring and the auto sear. Refer to Figure 34.

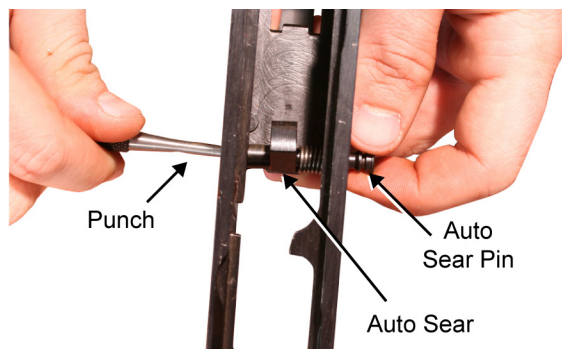


Figure 34. Installing the Auto Sear Retaining Pin.

NOTE

When installing the hammer assembly, ensure the wider side of the hammer is facing the rear of the receiver. Refer to Figure 35.

- d. Install the hammer assembly into the receiver, then insert the hammer retaining pin from the left side of the receiver. Ensure that the long leg of the auto sear spring is **BELOW** the hammer retaining pin and set it in the groove of the pin near the left side of the receiver. Refer to Figure 35.



Figure 35. Installing the Hammer Assembly and the Hammer Retaining Pin and Setting the Auto Sear Spring into Groove of the Hammer Retaining Pin.

NOTE

AK-47 models without interrupters will have dual hammer hooks on the trigger. Refer to Figure 36. In models with dual trigger hooks, the trigger must be installed **BEFORE** installing the selector lever.



Figure 36. Trigger with Dual Hammer Hooks.

NOTE

When installing the trigger and disconnecter assembly, use a punch as a slave pin. Insert the punch from the right side of the receiver and thread it through the holes in the trigger and disconnecter to hold them in place until the trigger retaining pin is installed.

- e. Install the trigger in the receiver. Refer to Figure 37.



Figure 37. Installing the Trigger.

**WARNING**

The hammer spring is under spring tension and the ends may be sharp enough to puncture the skin.

- f. Remove the wire, if used, from the ends of the hammer spring and carefully lower the legs of the hammer spring until they rest on top of the trigger. Refer to Figure 38.



Figure 38. Lowering the Hammer Spring Legs onto the Trigger.

- g. With the selector lever in the 12 o'clock position, install it on the right side of the receiver and rotate down to the SEMI position. Refer to Figure 39.

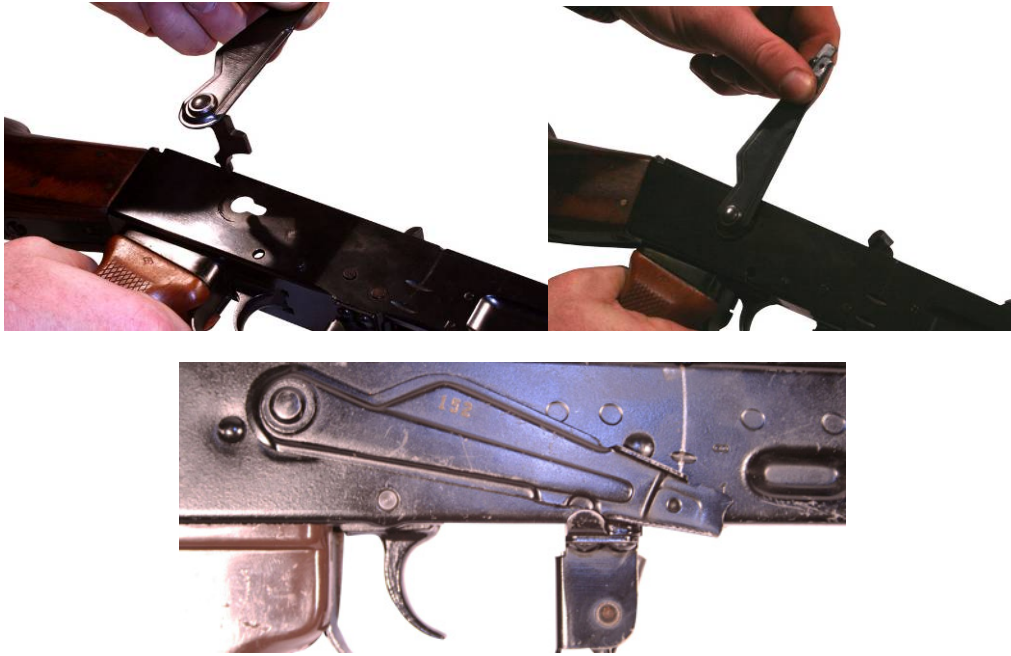


Figure 39. Installing the Selector Lever and Setting on SEMI.

- h. Install the disconnecter spring into the disconnecter. Refer to Figure 40.



Figure 40. Installing the Disconnecter Spring.

- i. Install the disconnecter into the trigger. Ensure that the hole in the disconnecter aligns with the hole in the trigger. Refer to Figure 41.

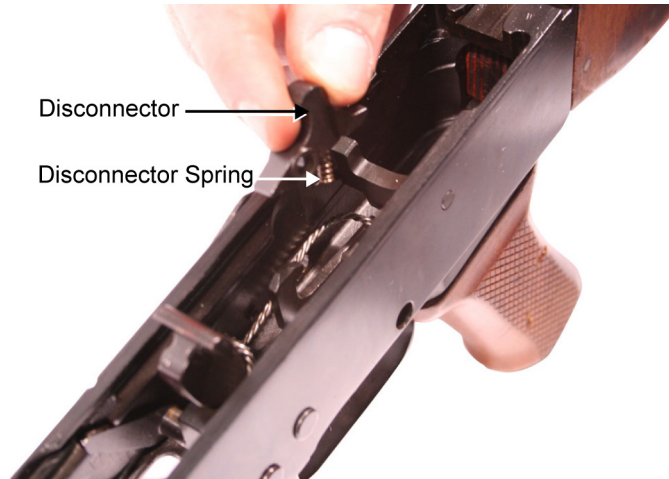


Figure 41. Installing the Disconnecter and Disconnecter Spring.

- j. If present, install the interrupter onto the trigger, ensuring that the notch in the base of the interrupter is seated on the forward edge of the right side of the trigger. Install the interrupter spring with the long leg of the spring pointing forward. Ensure that the hole in the base of the interrupter and the coil of the interrupter spring are aligned with the holes in the trigger. Refer to Figure 42.

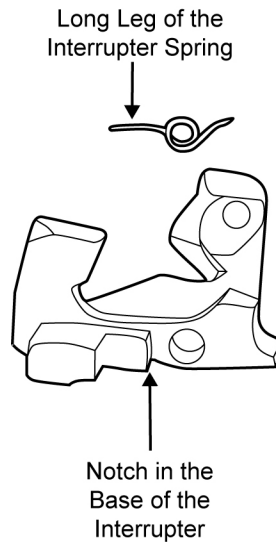


Figure 42. The Interrupter and Interrupter Spring.

- k. If present, push the long leg of the interrupter spring to the rear until it seats in the notch in the interrupter joint. Refer to Figure 43.

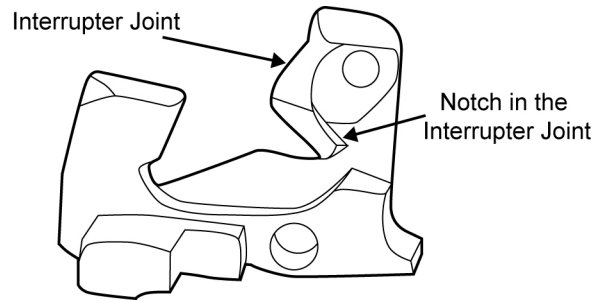


Figure 43. The Notch in the Interrupter Joint.

CAUTION

Only moderate pressure is necessary to install the retaining pins into the receiver. If the retaining pins are difficult to install, check to ensure that the grooves in the heads of the retaining pins are not caught on the receiver wall.

- l. Insert the trigger retaining pin from the left side of the receiver. Ensure to thread the pin through the holes in the trigger and the disconnecter. Ensure the long leg of the auto sear spring is on top of the trigger retaining pin and in the groove in the head of the pin.
- m. Push the hammer down until it locks in the cocked position. Refer to Figure 44.

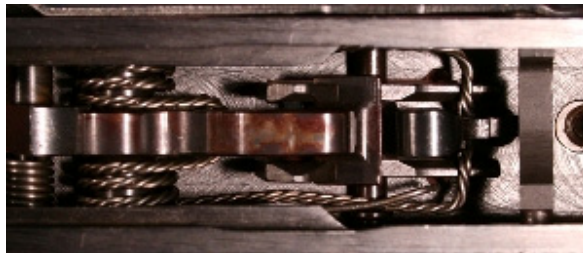


Figure 44. The Hammer in the Cocked Position.

CAUTION

Ensure that all retaining pins are fully seated in the receiver.

NOTE

Ensure that the long leg of the auto sear spring is properly installed. Refer to Figure 45. The long leg of the auto sear spring must be properly set into the grooves in the heads of the three retaining pins in the receiver in order to retain the pins in the receiver.

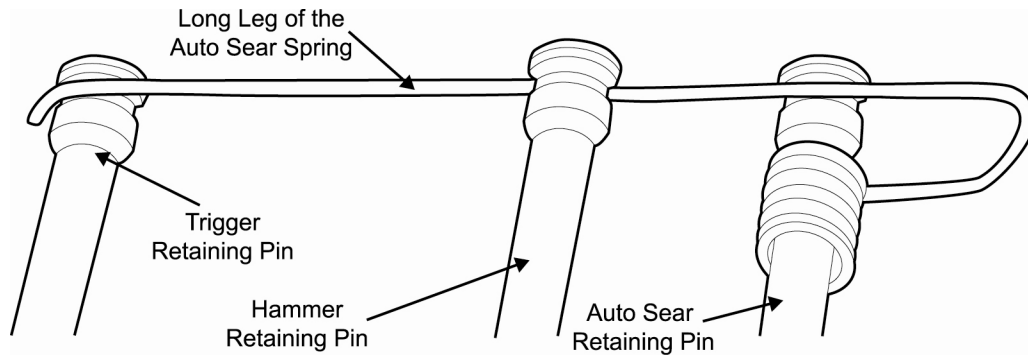


Figure 45. Proper Installation of the Long Leg of the Auto Sear Spring.

4. **Rear Sight.**

NOTE

When installing the rear sight leaf spring, restaking it into the rear sight base may be necessary.

- a. Use needle-nosed pliers to install the leaf spring into the rear sight base, ensuring that the dimple on the leaf spring corresponds to the hole in the rear sight base and that the wide, rear end is fully seated in the cut out in the top of the rear sight base. Refer to Figure 46.



Figure 46. Installing the Rear Sight Leaf Spring.

NOTE

Ensure the numbers on the rear sight assembly are facing upwards when installing the rear sight assembly.

- b. Holding the rear sight assembly at a 45 degree angle, push the studs on the bottom of the rear sight assembly down and forward into the grooves on the rear sight base until they are seated in the holes in the rear sight base. It may be necessary to use a dead blow mallet. Refer to Figure 47.



Figure 47. Installing the Rear Sight Assembly.

5. Gas Block.

- a. Install the gas selector from the right side of the gas block. Refer to Figure 48.



Figure 48. Installing the Gas Selector.

- b. Install the gas collar on the left side of the gas block over the end of the gas selector. Refer to Figure 49.



Figure 49. Installing the Gas Collar.

CAUTION

The C-clip can break and deform during installation. If the C-clip becomes bent or deformed, it should be replaced. Ensure that the open end of the C-clip is facing towards the muzzle.

- c. Install the C-clip on the left side of the gas block by pushing the open end of the C-clip against the end of the gas selector until it is seated around the end of the gas selector. Refer to Figure 50.

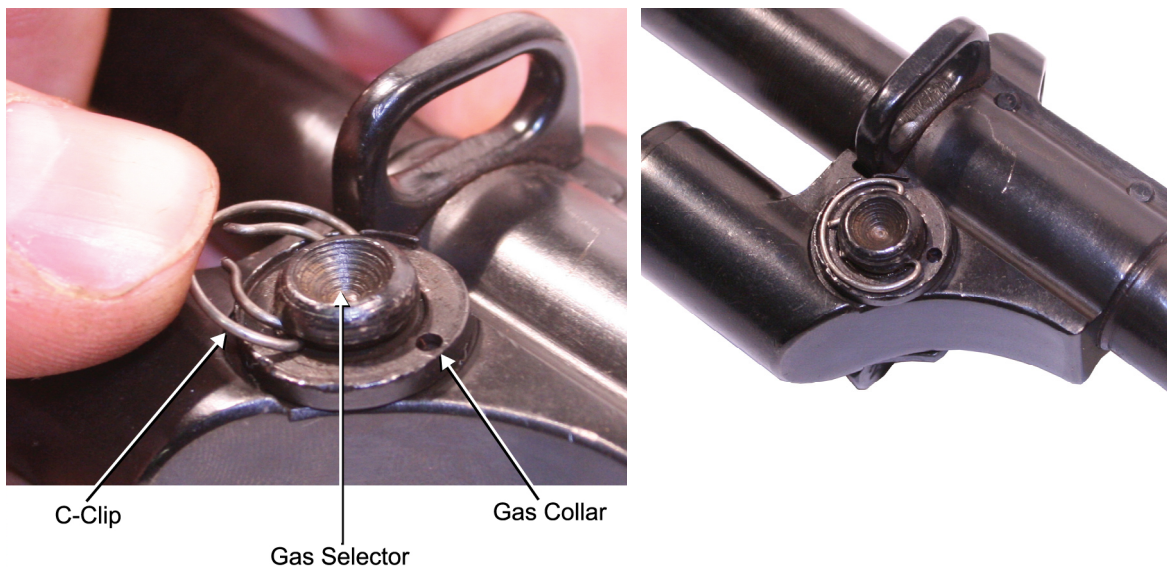


Figure 50. Installing the C-Clip and the C-Clip Installed.

- d. Switch the gas selector to the UP position (perpendicular to the barrel), indicating normal use. Refer to Figure 51.

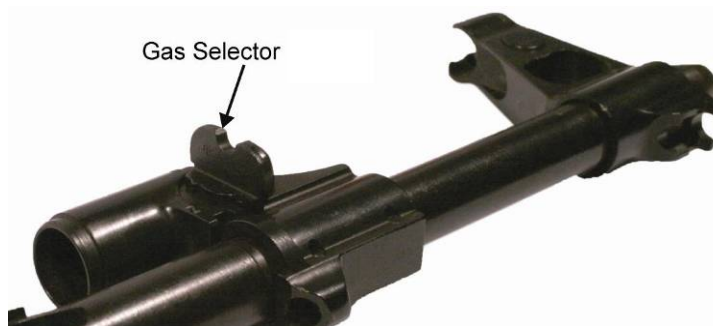


Figure 51. Gas Selector in the UP Position.

6. **Muzzle and Front Sight.**

- a. Using the front sight adjustment tool, install the windage drum into the front sight base. Refer to Figure 52.

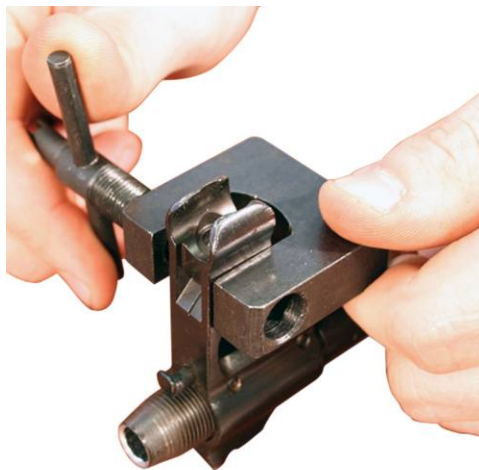


Figure 52. Installing the Windage Drum.

NOTE

The M249 front sight tool can also be used for working on the front sight.

- b. Using the front sight adjustment tool or the AK-47 combination tool, install the front sight post. Refer to Figure 50.



Figure 53. Installing the Front Sight Post.

- c. While using a punch to hold down the locking detent, turning the thread protector until it is seated tightly on the muzzle. Ensure that the locking detent is seated in one of the notches in the thread protector. Refer to Figure 54.

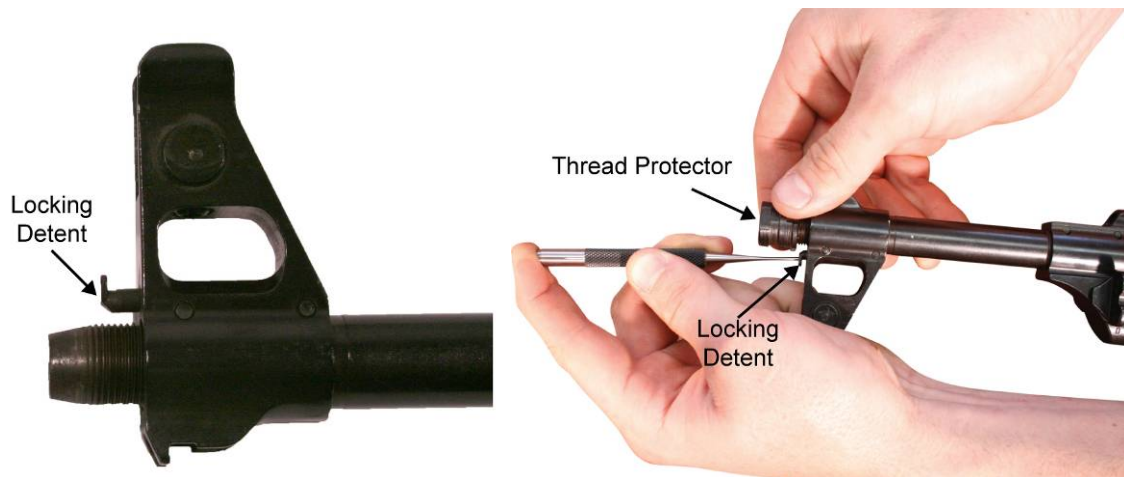


Figure 54. Installing the Thread Protector on the Muzzle.

END OF WORK PACKAGE

INTENTIONALLY BLANK

REAR SIGHT ASSEMBLY

THIS WORK PACKAGE DESCRIBES

Disassembly, Cleaning, Inspection and Repair, Lubrication, and Reassembly.

INITIAL SETUP

Maintenance Level

Organizational

References

WP 0009 00

WP 0013 00

WP 0025 00

Tools and Special Tools

E7900 tool kit

Equipment Conditions

Rear sight assembly removed (WP 0013 00)

DISASSEMBLY



WARNING

The elevation slide assembly is under spring tension. Use care when working on spring-loaded parts.

1. Depress the elevation slide assembly and remove it from the sight leaf. Refer to Figure 1.

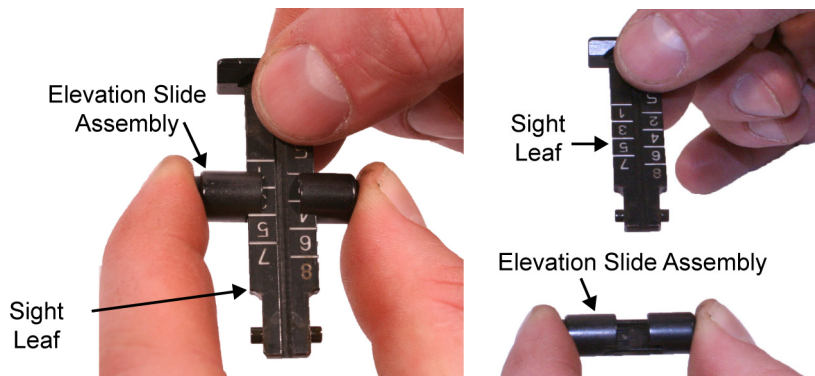


Figure 1. Depressing the Elevation Slide Assembly and Removing it from the Sight Leaf.

2. Disassemble the slide, spring, and catch. Refer to Figure 2.



Figure 2. Disassembled Slide, Slide Spring, and Slide Catch.

CLEANING

Clean and remove all carbon deposits from the weapon. Refer to TM 8370-50007-OR/1.

INSPECTION AND REPAIR

1. Inspect the sight leaf for cracks, deformities, and breaks. Replace the sight leaf if damaged.
2. Inspect the slide spring for spring tension, bends, or breaks. Replace the slide spring if damaged.
3. Inspect the slide and slide catch for cracks and burrs. Remove the burrs. Replace the slide or catch if damaged.

LUBRICATION

For all lubrication requirements refer to TM 8370-50007-OR/1.

REASSEMBLY

1. Assemble the slide, slide spring, and slide catch. Refer to Figure 3.



Figure 3. The Slide, Slide Spring, and Slide Catch.

2. Depress the elevation slide assembly and install it onto the sight leaf. Ensure the teeth on the elevation slide assembly mate with the teeth on the sight leaf. Refer to Figure 4.

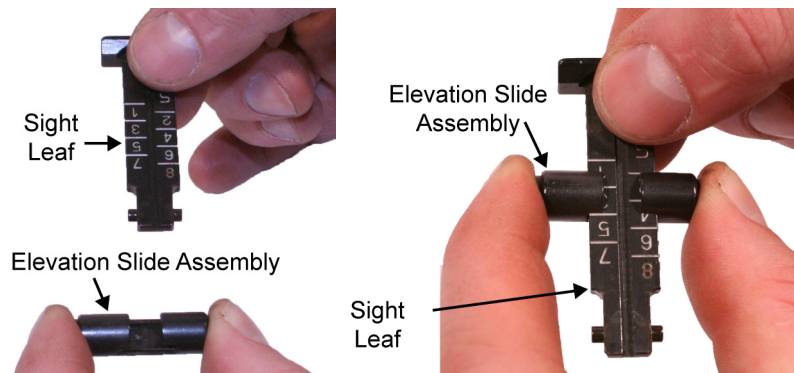


Figure 4. Depressing and Installing the Elevation Slide Assembly onto the Sight Leaf.

END OF WORK PACKAGE

FIXED BUTTSTOCK ASSEMBLY

THIS WORK PACKAGE DESCRIBES

Disassembly, Cleaning, Inspection and Repair, Lubrication, and Reassembly.

INITIAL SETUP**Maintenance Level**

Organizational

Tools and Special Tools

E7900 tool kit

References

TM 8370-50007-OR/1

WP 0013 00

WP 0025 00

Equipment Conditions

Fixed buttstock removed (WP 0013 00)

FIXED BUTTSTOCK ASSEMBLY**WARNING**

The buttplate and trapdoor are under spring tension. Use care when removing the trap door and buttplate.

1. Using a flat head screwdriver, remove the two buttplate screws from the buttplate. Refer to Figure 1.

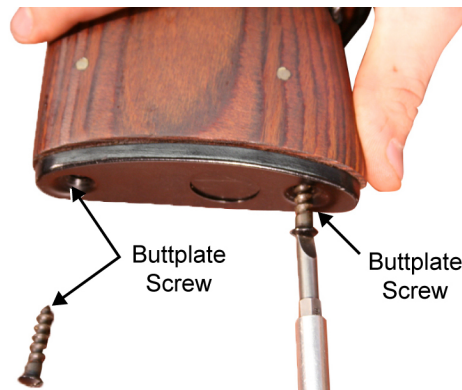


Figure 1. Removing the Buttplate Screws.

- Remove the buttplate, trap door, and buttstock spring from the buttstock. Refer to Figure 2.



Figure 2. Removing the Buttplate and Trap Door.

NOTE

Do not remove the buttstock spring unless replacement is needed.

CLEANING

Clean and remove all carbon deposits from the weapon. Refer to TM 8370-50007-OR/1.

INSPECTION AND REPAIR

- Check the fixed buttstock for cracks. Up to three cracks are acceptable. No cracks are acceptable in the critical areas (near pins and screws). Refer to Figure 3. Replace the buttstock if defective.

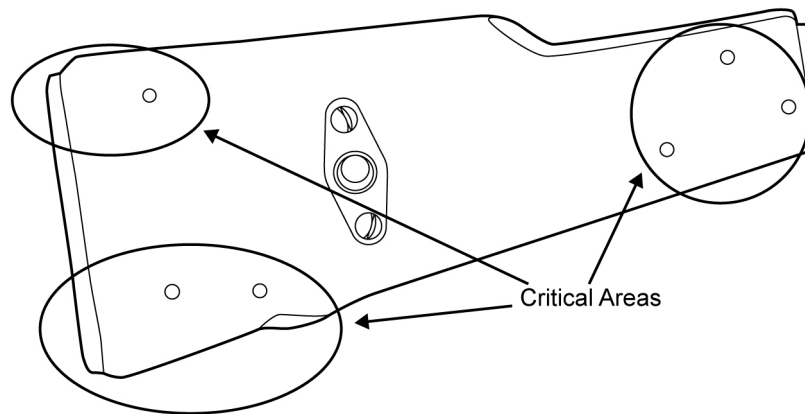


Figure 3. Critical Areas of the Buttstock.

- Check the screws for burrs. Remove the burrs. Replace the screws if damaged.
- Check the spring for breaks, distortion, and spring tension. Replace the spring if damaged.
- Check the buttplate and trap door for bends, cracks, and burrs. Remove the burrs. Replace the buttplate and trap door if damaged.
- Check the trap door spring for spring tension. Replace the trap door spring if damaged.

6. Check the fixed buttstock for front-to-rear movement or looseness between the buttstock and the receiver. If there is front-to-rear movement or looseness, remove the screw, clean the threads, apply thread locker, and reinstall the screw or replace it with a new buttstock screw.

LUBRICATION

For all lubrication requirements, refer to TM 8370-50007-OR/1.

REASSEMBLY

1. If removed, insert the buttstock spring, large end first, into the fixed buttstock.



WARNING

The trap door is under spring tension. Use care when installing the trap door and buttplate.

2. Place the trap door on the end of the fixed buttstock with the folded end facing the buttstock spring. Ensure that the screw hole in the trap door is aligned with the screw hole in the fixed buttstock. Refer to Figure 4.



Figure 4. The Trap Door Placed on the Fixed Buttstock.

3. Place the buttplate over the trap door ensuring that the hole in the buttplate is over the folded side of the trap door. Secure the buttplate with the two buttplate screws. Refer to Figure 5.



Figure 5. Installing the Buttplate and Buttplate Screws.

END OF WORK PACKAGE

INTENTIONALLY BLANK

REASSEMBLY OF WEAPON

THIS WORK PACKAGE DESCRIBES

Reassembly.

INITIAL SETUP**Maintenance Level**

Organizational

Equipment Conditions

Weapon disassembled into major components
(WP 0010 00)

References

TM 8370-50007-OR/1
WP 0010 00
WP 0017 00



Use care when installing and unloading spring-loaded parts. DO NOT interchange bolt assemblies from one weapon to another. DO NOT keep live ammunition in the work area. Failure to follow these warnings may cause injury or death to personnel.

REASSEMBLY

Refer to Figure 1.

1. Refer to TM 8370-50007-OR/1.
2. Install the handguards and gas tube onto the barrel. Install the cleaning rod under the barrel.
3. Install the bolt carrier assembly and bolt assembly and the spring and guide rod assembly into the receiver. Install the top cover onto the receiver.
4. Function check the weapon. Refer to WP 0017 00.

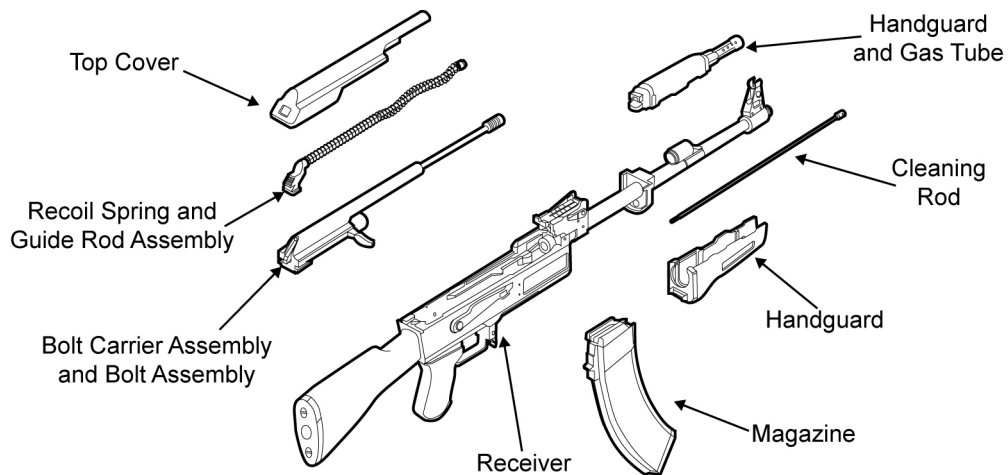


Figure 1. Major Components of the AK-47.

END OF WORK PACKAGE

FUNCTION CHECK

THIS WORK PACKAGE DESCRIBES

Function Check.

INITIAL SETUP**Maintenance Level**

Organizational

Equipment Conditions

Weapon cleared (TM 8370-50007-OR/1)

References

TM 8370-50007-OR/1

**WARNING**

Ensure that the weapon is clear prior to performing the following function checks. If the weapon fails any of the following function checks, attempt to repair it. If the weapon is beyond repair, replace it.

GENERAL

This section contains instructions for checking the functions of the AK-47 rifle.

FUNCTION CHECK

1. Perform the following function checks on assembled weapons only.
2. Remove the magazine, if inserted.
3. Place the selector lever on AUTO. Refer to Figure 1.



Figure 1. Selector Lever on AUTO.

4. Pull and hold the charging handle to the rear. Ensure that the chamber is clear. Release the charging handle.
5. Place the selector lever on SAFE. Refer to Figure 2.



Figure 2. Selector Lever on SAFE.

6. Pull the trigger. The hammer should not fall.
7. Place the selector lever on SEMI. Refer to Figure 3.



Figure 3. Selector Lever on SEMI.

8. Pull and hold the trigger to the rear. The hammer should fall.

9. While continuing to hold the trigger to the rear, charge the weapon.
10. Slowly release the trigger. An audible “click” should be heard. The hammer should not fall.
11. Place the selector lever on AUTO. Refer to Figure 4.



Figure 4. Selector Lever on AUTO.

12. Pull and hold the trigger to the rear. The hammer should fall.
13. While continuing to hold the trigger to the rear, charge the weapon and release the trigger. The hammer should not fall. An audible “click” should not be heard. The hammer should already be in the forward position and should not fall when the trigger is pulled again. Pull the trigger again. The hammer should not fall.
14. Repeat steps 12 and 13.
15. Leaving the hammer in the forward position, attempt to place the selector lever on SAFE. The selector lever SHOULD move to the SAFE position.
16. Place the weapon on SAFE, if it is not already.

END OF WORK PACKAGE

INTENTIONALLY BLANK

STOWAGE

THIS WORK PACKAGE DESCRIBES

Stowage.

INITIAL SETUP**Maintenance Level**

Organizational

Equipment Conditions

Weapon cleared (TM 8370-50007-OR/1)

References

TM 8370-50007-OR/1

**WARNING**

Before stowing a weapon, be sure to clear the weapon (TM 8370-50007-OR/1). Inspect the chamber to ensure it is empty and that no ammunition is in position to be chambered. Failure to follow this warning may cause injury or death to personnel.

STOWAGE

Prior to stowing the weapon in the arms room, perform the following procedures:

1. Clear weapon.
2. Place selector lever in SEMI position.
3. Pull trigger. Hammer should fall.
4. Place weapon on SAFE.
5. Place weapon on rack.

END OF WORK PACKAGE

INTENTIONALLY BLANK

PREPARATION FOR STORAGE AND SHIPMENT

THIS WORK PACKAGE DESCRIBES

Storage Procedures.

INITIAL SETUP**Maintenance Level**

Organizational

Equipment Conditions

Weapon cleared (TM 8370-50007-OR/1)

References

TM 8370-50007-OR/1
MCO P4450.7
WP 0009 00

STORAGE PROCEDURES**WARNING**

DO NOT store the weapon with live ammunition in either the chamber or magazine. Always assume that every weapon is loaded until it is determined through visual and physical inspection that it is not. Procedures for clearing and unloading the weapon are outlined in TM 8370-50007-OR/1. Failure to follow these warnings may cause injury or death to personnel.

1. **Storage Procedures.**
 - a. Ensure that the chamber and magazine do not contain live ammunition.
 - b. Inspect the bore and chamber and apply a medium coat of CLP.
 - c. Apply a light coat of CLP to all other metal surfaces of the weapon to provide extra lubrication and corrosion protection.
2. **Storage for Extended Periods.** When the weapon is to be stored for an extended period (greater than 90 days), follow the procedures outlined in MCO P4450.7, *Preparation for Storage*. Ensure that the weapon is thoroughly cleaned as outlined in WP 0009 00.
3. **Packaging.** If required, packaging for shipping or storage that will not exceed 90 days shall be done as follows:
 - a. Clean the weapon in accordance with WP 0009 00.
 - b. Wrap the weapon with MIL-B-12 waterproof material.

-
- c. Place the weapon in a barrier bag MIL-B-117, Type I, Class C, or wrap it with MIL-B-121, Type I, Grade A, and seal with tape, PPP-T-76.
 - d. Place one or more of the item(s) in minimum size container. Block and brace the items in accordance with MIL-STD-1186. Cushion the weapon and similar weight items with PPP-C-843 and use PPP-B-320 as filler to create a tight pack.
 - (1) Fiber board containers shall be in accordance with PPP-B-636 and may be Class Domestic. Gross weight and size of the material shall determine the grade of the fiberboard container. PPP-B-640 may also be used.
 - (2) Wood containers shall be in accordance with PPP-B-601 or PPP-B-621.
 - e. Equivalent materials may be used.
4. NSNs are not assigned to all the specific material. If it is necessary to specify an NSN in the TMs, the packing materials will have to be spared and part numbers and NSNs assigned.
 5. The specifications used are:
 - a. MIL-B-117 - Bag, sleeve and tubing - interior packaging (NSN 8135-00-543-6574)
 - b. MIL-B-121 - Barrier material, greaseproof, waterproof, flexible (NSN 8135-00-753-4661)
 - c. MIL-STD-129 - Marking for shipment and storage
 - d. MIL-STD-1186 - Cushioning, anchoring, bracing, blocking and waterproofing with appropriate test methods
 - e. PPP-B-601 - Boxes, wood, cleated plywood
 - f. PPP-B-621 - Boxes, wood, nailed and locked - corner
 - g. PPP-B-636 - Boxes, shipping, fiberboard
 - h. PPP-B-640 - Boxes, fiberboard, corrugated, triple-wall
 - i. PPP-C-843 - Cushioning material, cellulosic
 - j. PPP-F-320 - Fiberboard, corrugated and solid sheet rock (container grade), and cut shapes
 - k. PPP-T-76 - Tape, packaging, paper.

END OF WORK PACKAGE

FINAL INSPECTION AND FUNCTION TEST

THIS WORK PACKAGE DESCRIBES

Final Inspection and Function Test.

INITIAL SETUP**Maintenance Level**

Organizational

References

WP 0017 00

WP 0021 00

WP 0025 00

Tools and Special Tools

E7900 tool kit

AK-47 gage kit

Equipment Conditions

Weapon cleared (TM-8370-50007-OR/1)

**WARNING**

DO NOT keep live ammunition near the work area. Failure to follow this warning may cause injury or death to personnel.

FINAL INSPECTION

1. Visually inspect the general appearance of the weapon. The weapon should appear almost new. All metal surfaces should have a dull, rust- or corrosion-resistant finish with no burrs or deep scratches.
2. Visually inspect the barrel for serviceability. Check for the following:
 - a. The barrel must be straight, clean, and free of rust, powder fouling, bulges, and rings. Fine pitting is allowable.
 - b. Ensure that the barrel assembly does not rotate or move within the receiver.
 - c. Using moderate hand pressure, check for rotational movement of the front sight in relation to the barrel. If movement between the front sight and barrel exists, the barrel must be replaced.
3. Visually inspect the rifle for missing parts. All parts must be securely attached and all modifications must be applied. Steel parts must be rust-free. Spring pins must be secure and screws must be tight.
4. Functionally inspect the bolt carrier assembly, using the following procedures:
 - a. Charge the weapon with a fluid motion, ensuring that the bolt carrier does not get stuck to the rear.
 - b. Ensure that the bolt locks and unlocks freely.

-
5. Function check the weapon with the selector lever set in the SAFE, SEMI, and AUTO positions. Any portion of this check may be used alone to determine the operating condition of any specific firing position selected.
 6. Check the rear sight assembly as follows:
 - a. Ensure that the leaf spring has positive tension on the rear sight assembly.
 - b. Ensure that the elevation slide spring clicks into place on the sight leaf.
 7. Perform the following additional checks:
 - a. Check headspace using the headspace “go” gage, P/N 1775011 (WP 0021 00), and the headspace “no-go” gage, P/N 1775012 (WP 0021 00).
 - b. Check firing pin protrusion using the firing pin protrusion gage, P/N 1775015 (WP 0021 00).
 - c. Check barrel straightness using the barrel straightness gage, P/N 1775014 (WP 0021 00).
 - d. Press the magazine release to check for spring tension.
 - e. Inspect the front sight and rear sight. Ensure that proper adjustment is possible with each assembly.

FUNCTION TEST

Perform a function check. Refer to WP 0017 00.

END OF WORK PACKAGE

GAGING PROCEDURES

THIS WORK PACKAGE DESCRIBES

Gaging.

INITIAL SETUP

Maintenance Level

Organizational

References

WP 0011 00
WP 0025 00

Tools and Special Tools

E7900 tool kit
AK-47 gage kit

Equipment Condition

Top cover removed (WP 0011 00)
Recoil spring and guide rod assembly removed (WP 0011 00)

GAGING

NOTES

Initial gaging is required upon receipt of the weapon. All weapons must be gaged once annually.

The gages in the AK-47 gage kit are precision tools. When using the gages, handle them with care and use LIGHT pressure to avoid damaging them.

Gaging requirements along with pre-fire inspection (PFI) are to be performed within 30 days of each live fire evolution.



Figure 1. AK-47 Gage Kit.

FIRING PIN PROTRUSION GAGE
NOTE

The “go” side of the AK-47 firing pin protrusion gage is the side that reads “GO.” The “no-go” side of the AK-47 firing pin protrusion gage is the side that reads “NO-GO” and has a red dot. Refer to Figure 2.



Figure 2. Firing Pin Protrusion Gage.

1. With the rear of the bolt on a flat surface, sweep the “go” side of the gage across the firing pin. The gage should run freely over the pin. Refer to Figure 3.



Figure 3. Using the “Go” Side of the Firing Pin Protrusion Gage.

2. If the gage catches on the firing pin, replace the firing pin.
3. With the rear of the bolt on a flat surface, sweep the “no-go” side of the gage across the firing pin. The gage should catch and not move freely over the pin. Refer to Figure 4.



Figure 4. Using the “No-Go” Side of the Firing Pin Protrusion Gage.

4. If the “no-go” side of the gage does not catch on the firing pin, the firing pin is too short and the bolt is defective.

BORE EROSION GAGE

1. Hold the bore erosion gage by the ball handle. Refer to Figure 5. Insert the bore erosion gage into the bore. Refer to Figure 6.



Figure 5. The Bore Erosion Gage.



Figure 6. Inserting the Bore Erosion Gage into the Breech End of the Barrel.

2. Lightly push the bore erosion gage into the barrel until it seats on the bore.
3. The first line of the bore erosion gage is the warning line. If the bore erosion gage goes into the index line past the warning line, more frequent gaging should be conducted. Refer to Figure 7.
4. The second line of the bore erosion gage is the reject line. If the bore erosion gage goes into the index line past the reject line, the barrel is defective and the weapon needs to be replaced. Refer to Figure 7.

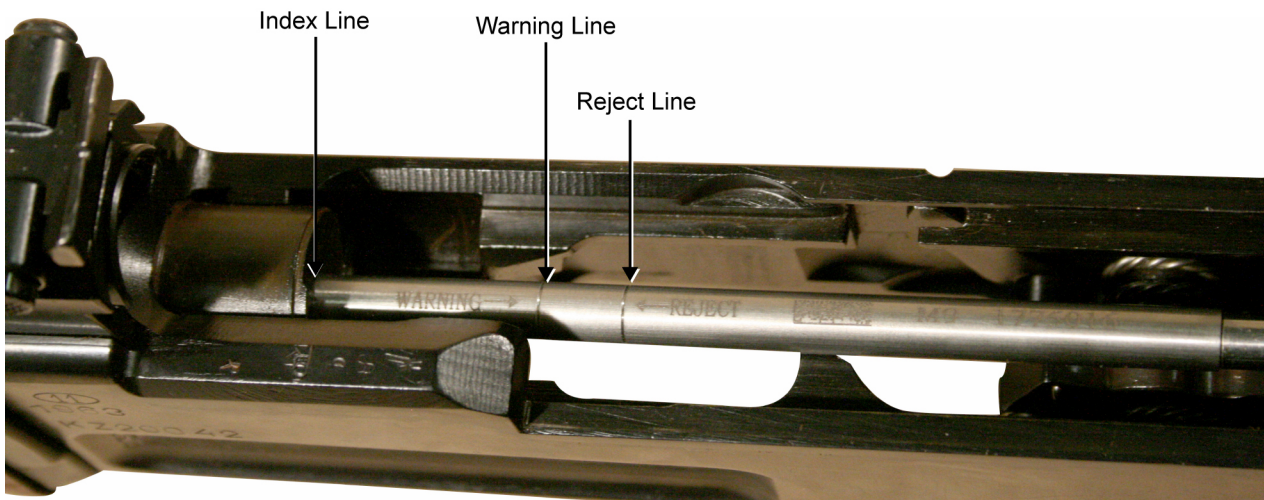


Figure 7. Bore Erosion Gage Warning and Reject Lines.

BORE STRAIGHTNESS GAGE**CAUTION**

Always drop the straightness gage from the chamber to the muzzle. Do not let the bore straightness gage fall to the deck. This may damage the gage. Refer to Figure 8.



Figure 8. Bore Straightness Gage.

1. Holding the weapon vertically, with the buttstock up, place your hand under the muzzle to prevent the bore straightness gage from hitting the deck and being damaged. Drop the bore straightness gage down through the barrel, catching it in hand. Refer to Figure 9.



Figure 9. Dropping the Bore Straightness Gage through the Chamber.

2. The bore straightness gage should fall freely through the barrel and out of the muzzle. Refer to Figure 10.



Figure 10. Bore Straightness Gage Coming out of the Muzzle.

3. If the bore straightness gage does not fall freely, run a patch through the barrel and repeat step 1.
4. If the bore straightness gage again does not pass through the barrel freely, the barrel is defective and the weapon needs to be replaced.

HEADSPACE “GO” GAGE

CAUTION

When pushing the bolt closed during headspace gaging, be sure to use LIGHT pressure. Failure to do so may damage the weapon.



Figure 11. The Headspace “Go” Gage.

1. Pull the bolt carrier to the rear and insert the headspace “go” gage into the chamber. Refer to Figure 12.



Figure 12. Inserting the Headspace “Go” Gage.

2. Ensure the headspace “go” gage is fully seated in the chamber. Refer to Figure 13.



Figure 13. Headspace “Go” Gage Fully Seated in the Chamber.

3. Using LIGHT pressure, push the bolt carrier forward. The bolt should lock on the headspace “go” gage. If the bolt does not lock on the “go” gage, replace the bolt and regage. If the second bolt does not either lock, replace the weapon. Refer to Figure 14.



Figure 14. Bolt Locked.

4. Pull the bolt carrier to the rear and remove the headspace “go” gage.

HEADSPACE “NO-GO” GAGE



Figure 15. The Headspace “No-Go” Gage.

1. Pull the bolt carrier to the rear and insert the headspace “no-go” gage into the chamber. Refer to Figure 16.



Figure 16. Inserting the Headspace “No-Go” Gage.

2. Ensure the headspace “no-go” gage is fully seated in the chamber. Refer to Figure 17.



Figure 17. Headspace “No-Go” Gage Fully Seated in the Chamber.

- Using LIGHT pressure, push the bolt closed. The bolt should NOT lock on the “no-go” gage. If the bolt does lock on the “no-go” gage, replace the bolt and regage. If the second bolt also locks, replace the weapon. Refer to Figure 18.



Figure 18. Bolt NOT Locked.

- Pull the bolt carrier to the rear and remove the headspace “no-go” gage.

PLAIN PLUG “NO-GO” GAGE

The plain plug “no-go” gage checks for the out-of-round condition of the firing pin hole in the bolt face. Refer to Figure 19.



Figure 19. Plain Plug “No-Go” Gage.

- Try to insert the pin of the plain plug “no-go” gage into the firing pin hole in the bolt face by slowly rotating the gage.
- If the pin enters the hole at any point, and enters up to the notch on the pin of the plain plug “no-go” gage, the bolt is defective and needs to be replaced.

END OF WORK PACKAGE

CHAPTER 4
AUXILIARY EQUIPMENT

INTENTIONALLY BLANK

AUXILIARY EQUIPMENT - GENERAL

GENERAL

The following auxiliary equipment items are used in conjunction with the AK-47 rifle:

1. Combination tool kit. Refer to Figure 1.

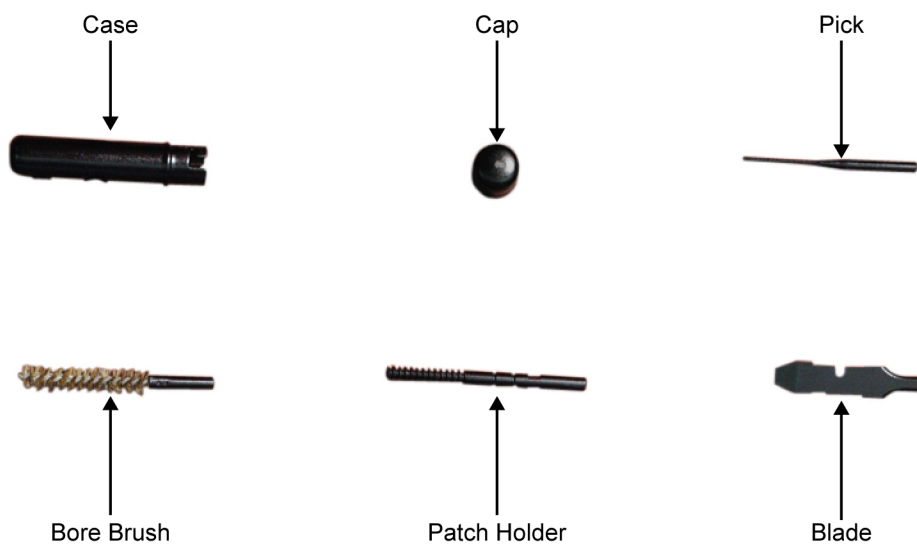


Figure 1. Combination Tool Kit.

2. Bayonet and bayonet scabbard. Refer to Figure 2.



Figure 2. Bayonet and Bayonet Scabbard.

3. Sling. Refer to Figure 3.



Figure 3. Sling.

END OF WORK PACKAGE

CHAPTER 5
SUPPORTING INFORMATION

INTENTIONALLY BLANK

REFERENCES

SCOPE

This work package lists all forms, field manuals, technical manuals, tables, regulations, standards, and miscellaneous publications referenced in this manual.

TECHNICAL BULLETINS/INSTRUCTION/MANUALS/ORDERS

Preparation for Storage MCO P4450.7
 Weapon Custody Receipt Card..... NAVMC 10520
 Equipment Repair Order NAVMC 10245
 Memorandum Receipt for Individual Weapons and Accessories NAVMC 10576
 Equipment Repair Order Shopping/Transaction List..... NAVMC 10925
 Ammunition and Explosives Safety Standards.....PAM 385-64
 Standards for Overseas Shipment or Domestic Issue of Small Arms, Aircraft Armament,
 Towed Howitzers, Mortars, Recoilless Rifles, Rocket Launchers, and Associated Fire
 Control Equipment TB 9-1000-247-34_
 Infantry Weapons Gage Calibration Program (IWGCP) TI 4733-15/11_
 Organizational Corrosion Prevention and Control Procedures for USMC Equipment TM 4795-12/1_
 Ground Equipment Record Procedures..... TM 4700 -15/1_
 Procedures for Destruction of Equipment.....TM 750-244-7
 Military Use of Cleaner, Lubricant, and Preservative (CLP) for Weapons and
 Support Equipment TM 9150-15/1_
 Operators Manual for Rifle, 7.26 mm, AK-47..... TM 8370-50007-OR/1

FORMS

Recommended Changes to Technical Publications NAVMC 10772
 Report of Discrepancy (ROD)SF 364

END OF WORK PACKAGE

INTENTIONALLY BLANK

EXPENDABLE AND DURABLE ITEMS LIST

SCOPE

Table 1 contains expendable and durable items for the support and operation of the AK-47 rifle.

EXPLANATION OF COLUMNS

1. **Column (1) - Item Number.** This number is assigned to the entry in the list.
2. **Column (2) - National Stock Number (NSN).** This is the NSN assigned to an item and is used when requisitioning the item.
3. **Column (3) - Description, CAGEC, and Part Number.** This provides other information, if available, that may be needed to identify the item.
4. **Column (4) - Unit of Measure (U/M).** This code shows the physical measurement or count of an item, such as gallon (GAL), pint (PT), dozen (DZ), bundle (BDL), each (EA), bottle (BTL), package (PKG), book (BK), can (CN), or bale (BE).

Table 1. Expendable and Durable Items for the AK-47 Rifle.

(1) Item Number	(2) National Stock Number (NSN)	(3) Description, CAGEC, and Part Number	(4) U/M
1	1005-00-444-6602	Brush, cleaning, tools and parts	EA
2	6850-00-965-2332	Carbon removing compound	GAL
3	9150-01-102-1473	Cleaner, lubricant, and preservative (CLP)	EA
	9150-01-079-6124	CLP - 4 oz (118.30 mL) bottle	BTL
	9150-01-054-6453	CLP - 1 pt (0.47 L) bottle	BTL
	9150-01-053-6688	CLP - 1 gal (3.78 L) can	CN
4	9920-00-292-9946	Cleaner, tobacco pipe, cotton turf, wire core, pipe cleaner (36 per pkg)	PKG
5	5350-00-221-0872	Cloth, abrasive	SH
6	8415-00-823-7458	Gloves, chemical and oil protective Size 9	PR
	8415-00-823-7459	Size 10	PR
	8415-00-823-7460	Size 11	PR
7	9150-01-260-2534	Lubricant, solid film 16 oz (473.18 mL) spray can	CN
8	9150-00-292-9689	Lubricant, arctic, weapons (LAW) 1 qt (0.95 L) can	CN

Table 1. Expendable and Durable Items for the AK-47 Rifle - Continued.

(1) Item Number	(2) National Stock Number (NSN)	(3) Description, CAGEC, and Part Number	(4) U/M
9	9150-00-935-6597 9150-00-889-3522 9150-00-687-4241 9150-00-753-4686	Lubricant, semi-fluid, automatic weapons, (LSA) 2 oz (59.15 mL) plastic bottle 4 oz (118.30 mL) plastic bottle 1 qt (0.95 L) can 1 gal. (3.79 L) can	BTL BTL CN CN
10	3990-00-795-3595	Pan, wash (box, tote)	EA
11	6850-00-826-0981	Penetrant kit	KT
12	7290-00-205-1711	Rag, wiping 50 lb (22.68 kg) bdl	BDL
13	6850-00-281-1985	Solvent, dry cleaning 1 gal. (3.79 L) can	CN
14	6850-01-474-2319	Solvent, general MIL-PRF-680 Type II 1 gal. (3.79 L)	GAL
	6850-01-474-2317	5 gal. (18.93 L)	GAL
	6850-01-474-2316	55 gallon drum	DR
15	1005-00-288-3565	Swab, cleaning, small arms (7.62 patch)	SH

END OF WORK PACKAGE

TOOL IDENTIFICATION LIST (INCLUDES SPECIAL TOOLS)

SCOPE

This work package lists the common tools and special tools authorized for support of the AK-47 rifle.

EXPLANATION OF COLUMNS

1. **Column (1) - Item Number.** This column indicates the number of the figure, if available, that shows the item.
2. **Column (2) - Item Name.** This column lists the item by noun nomenclature and other descriptive features.
3. **Column (3) - National Stock Number (NSN).** This column lists the NSN assigned to an item and is used when requisitioning the item.
4. **Column (4) - Part Number.** This column indicates the primary number used by the manufacturer which controls the design and characteristics of the item by means of its engineering drawings, specifications, standards, and inspection requirements to identify an item or range of items.
5. **Column (5) - Unit of Measure (U/M).** This column shows the count of an item when issued, such as each (EA), set (Set), package (PKG), book (BK), or bale (BE).

Table 1. Tools Identification List for AK-47 Rifle.

(1) Item Number	(2) Item Name	(3) National Stock Number (NSN)	(4) Part Number	(5) U/M
1	Gage kit, AK-47	TBD	N/A	Set
2	Gage, bore erosion	TBD	1775016	EA
3	Gage, bore straightness	TBD	1775014	EA
4	Gage, firing pin protrusion	TBD	1775015	EA
5	Gage, headspace "go"	TBD	1775011	EA
6	Gage, headspace "no go"	TBD	1775012	EA
7	Gage, plain plug "no go"	TBD	1775013	EA
8	Tool, front sight adjustment	TBD	N/A	EA
9	Tool, scraper	TBD	N/A	EA
10	Tool kit, USMC E7900	5180-01-504-5663	TK-2111	EA

Figures 1 through 8 represent the items 1 through 8 listed in Table 1.



Figure 1. Gage Kit, AK-47.



Figure 2. Gage, Bore Erosion (1775016).



Figure 3. Gage, Bore Straightness (1775014).



Figure 4. Gage, Firing Pin Protrusion (1775015).



Figure 5. Gage, Headspace "Go" (1775011).



Figure 6. Gage, Headspace "No-Go" (1775012)



Figure 7. Gage, Plain Plug "No-Go" (1775013).

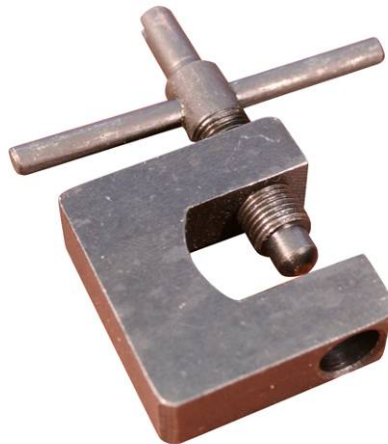


Figure 8. Tool, Front Sight Adjustment

END OF WORK PACKAGE

INTENTIONALLY BLANK

REPAIR PARTS LIST (RPL) INTRODUCTION

SCOPE

This repair parts list (RPL) authorizes spares, repair parts, and other special support equipment required for the performance of organizational maintenance of the AK-47 rifle. It authorizes the requisitioning, issue, and disposition of spares and repair parts indicated by the source, maintenance, and recoverability (SMR) codes. Parts lists are composed of functional groups listed in figure and item number sequence.

EXPLANATION OF COLUMNS

1. **Item No. (Column 1).** The item number indicates the number used to identify items called out in an illustration.
2. **SMR Code (Column 2).** The SMR code is a five-position code containing supply and requisition information, maintenance level authorization criteria, and disposition instructions as shown in the following manner. Refer to Table 1 for an explanation of the five positions in the SMR code. Refer to Tables 2-5 for explanations of the source codes, maintenance codes, and recoverability codes that make up the SMR code.

Table 1. SMR Code Positions.

Source Code	Maintenance Code		Recoverability Code
XX 1st and 2nd positions How to obtain an item.	X 3rd position Who can install, replace, or use the item.	X 4th position Who can perform repair* on the item.	X 5th position Who determines the disposition action on an unserviceable item.

NOTE

Complete repair: maintenance capacity, capability, and authority to perform all corrective maintenance tasks of the repair function in a user environment in order to restore serviceability to a failed item.

- a. Source Code. The source code indicates how to obtain an item needed for maintenance, repair, or overhaul of equipment and is entered in the first and second positions of the SMR code as shown in Table 2.

Table 2. Source Codes.

Code	Application/Explanation
PA	Item: Stocked
PB	Item: Stocked, insurance
PC	Item: Stocked, deteriorative
PD	Item: Support, initial issue or outfitting and stocking only for additional initial issue.
PE	Equip: Support, stocked, initial issue, or outfitting of specified maintenance activities (also used for "special tools").
PF	Equip: Support, non-stocked, and centrally procured on demand.
PG	Item: Stocked, for sustained support, uneconomical to produce at later time.

Table 2. Source Codes - Continued.

Code	Application/Explanation
KD	Items with these codes are not to be requested/requisitioned individually. These items are part of a kit authorized to the maintenance level indicated in the 3rd position of the SMR code. The complete kit must be requisitioned and applied for this weapon.
KF	
KB	
MO	Items with these codes are not to be requisitioned individually. They must be made from bulk material identified by the part number in the description column. No bulk material items are applicable for this weapon.
MF	
MH	
ML	
MD	
AO	Items with these codes are not to be requested/requisitioned individually. The parts that make the assembled items must be requisitioned, fabricated, or assembled at the level of maintenance indicated by source code. If the 3rd position code of the SMR code authorizes the item to be replaced, but the source code indicates the item is assembled at a higher level, order the item from the higher level of maintenance.
AF	
AH	
AD	
XA	Do not requisition an XA-coded item. Order its next higher assembly. (Also refer to the NOTE below).
XB	If an XB item is not available from salvage, order it using the CAGEC and part number given.
XC	XC installation drawing, diagram, instruction sheet, and field service drawing identified by the manufacturer's part number.
XD	XD are items not stocked. Order an XD-coded item through normal supply channels using the CAGEC and part number given.

NOTE

Cannibalizing or controlled exchange, when authorized, may be used as a source of supply for items with the above source codes, except for those coded XA. Items coded PC are subject to deterioration.

- b. Maintenance Code. The maintenance code indicates the levels of maintenance authorized to use and repair the support items. The maintenance codes are entered in the third and fourth positions of the SMR code format as follows:

- (1) The maintenance code entered in the third position indicates the lowest maintenance level authorized to remove, replace, and use an item. Refer to Table 3 for an explanation of the maintenance code that indicates the level of maintenance required.

Table 3. Third Position Maintenance Codes.

Code	Application/Explanation
C	Crew or operator maintenance done within unit maintenance.
O	Organizational level can remove, replace, and use the item.
F	Third echelon can remove, replace, and use the item.
H	Fourth echelon can remove, replace, and use the item.
L	Specialized repair activity can remove, replace, and use the item.
D	Depot level can remove, replace, and use the item.

- (2) The maintenance code entered in the fourth position indicates whether the item is to be repaired at the lowest maintenance level with the capability to perform complete repair (i.e., all authorized maintenance functions).

NOTE

Some limited repair may be done on the item at a lower level of maintenance, if authorized by the SMR codes.

Table 4. Fourth Position Maintenance Codes.

Code	Application/Explanation
O	Organizational level is the lowest level that can completely repair the item.
F	Intermediate third echelon is the lowest level that can completely repair the item.
H	The lowest maintenance level capable of complete repair of the support item is the general support level.
D	Depot level is the lowest level that can completely repair the item.
L	Specialized repair activity (designated the specialized repair activity) is the lowest level that can completely repair the item.
Z	Non-repairable. No repair is authorized.
B	No repair authorized. No parts or special tools are authorized for maintenance of a B-coded item. However, the item may be reconditioned by adjusting or lubricating at the user level.

- c. Recoverability Code. The recoverability code is assigned to support items to indicate the disposition action on unserviceable items. The recoverability code is entered in the fifth position of the SMR code format. Refer to Table 4 for code explanations.

Table 5. Recoverability Codes.

Code	Application/Explanation
Z	Non-repairable item. When unserviceable, condemn and dispose of the item at the level of maintenance shown in the third position of the SMR code.
O	Repairable item. When uneconomically repairable, condemn and dispose of at the organizational level.
F	Repairable item. When uneconomically repairable, condemn and dispose of at the third echelon level.
H	Repairable item. When uneconomically repairable, condemn and dispose of at the fourth echelon level.
D	Repairable item. When uneconomically repairable, condemn and dispose of at the depot level.
L	Repairable item. Condemnation and disposal not authorized below specialized repair activity.
A	Item requires special handling or condemnation procedures because of specific reasons (e.g., precious metal content, high dollar value, or hazardous material). Refer to the appropriate manuals/directives for specific instructions.

- NSN (Column 3).** The national stock number for the item is listed in this column.
- CAGEC (Column 4).** The commercial and government entity code is a 5-digit code used to identify the manufacturer, distributor, or government activity that supplies the item.

-
5. **Part Number (Column 5)**. Indicates the primary number used by the manufacturer that controls the design and characteristics of the items by means of its engineering drawings, specifications, standards, and inspection requirements to identify an item or range of items.

NOTE

When an NSN is used to requisition an item, the item received may be a different part number from the part ordered.

6. **Item Identification (Column 6)**. This column includes the following information:
- Federal item name and, when required, a minimum description identifying the items.
 - The statement END OF FIGURE appears just below the last item description in columns 6 and 7 for a given figure.
7. **Qty (Column 7)**. The quantity (Qty) column indicates the quantity of the item used in the breakout shown on the illustration figure, which is prepared for a functional group, sub-functional group, or an assembly. The letter V appearing in this column in lieu of a quantity indicates the quantity is variable and may vary from application to application.

HOW TO LOCATE REPAIR PARTS

WP 0027 00 contains the repair parts and special tools listings.

- Unknown national stock number (NSN) or part number.
 - Identify the item from the illustration and note the item number.
 - Look in the repair parts list (RPL) for the figure and item numbers. The NSNs and part numbers are on the same lines as the associated item numbers.
- Known NSN or part number.
 - Using the NSN or part number, locate the item in the RPL. Note the pertinent information.
 - Verify the identity of the item.

END OF WORK PACKAGE

INTENTIONALLY BLANK

REPAIR PARTS LIST (RPL)

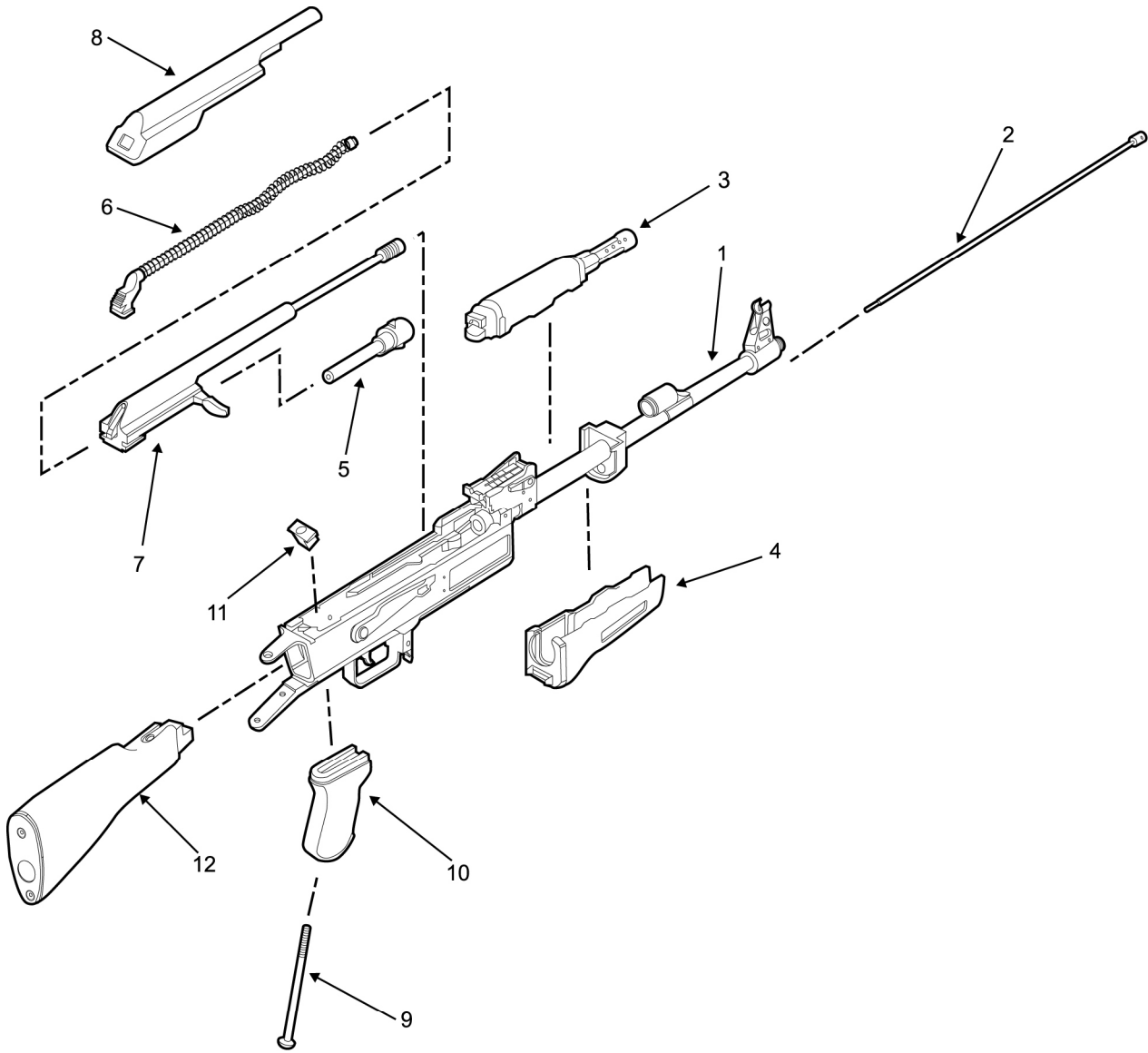


Figure 1. AK-47 Rifle.

Table 1. AK-47 Rifle.

(1) Item No.	(2) SMR Code	(3) NSN	(4) CAGEC	(5) Part Number	(6) Description and Usable on Codes (UOC)	(7) Qty.
Figure 1. AK-47 rifle						
1	PAOZZ	TBD	TBD	TBD	Assembly, receiver (see Figure 2 for breakdown)	1
2	PAOZZ	TBD	TBD	TBD	Rod, cleaning	1
3	PAOZZ	TBD	TBD	TBD	Handguard, upper and tube, gas	1
4	PAOZZ	TBD	TBD	TBD	Handguard, lower	1
5	PAOZZ	TBD	TBD	TBD	Assembly, bolt (see Figure 3 for breakdown)	1
6	PAOZZ	TBD	TBD	TBD	Assembly, recoil spring and guide rod (see Figure 3 for breakdown)	1
7	PAOZZ	TBD	TBD	TBD	Assembly, bolt carrier (see Figure 3 for breakdown)	1
8	PAOZZ	TBD	TBD	TBD	Cover, top	1
9	PAOZZ	TBD	TBD	TBD	Screw, pistol grip	1
10	PAOZZ	TBD	TBD	TBD	Grip, pistol	1
11	PAOZZ	TBD	TBD	TBD	Block. mounting, pistol grip screw	1
12	PAOZZ	TBD	TBD	TBD	Assembly, buttstock, fixed (see Figure 5 for breakdown)	1
End of figure						

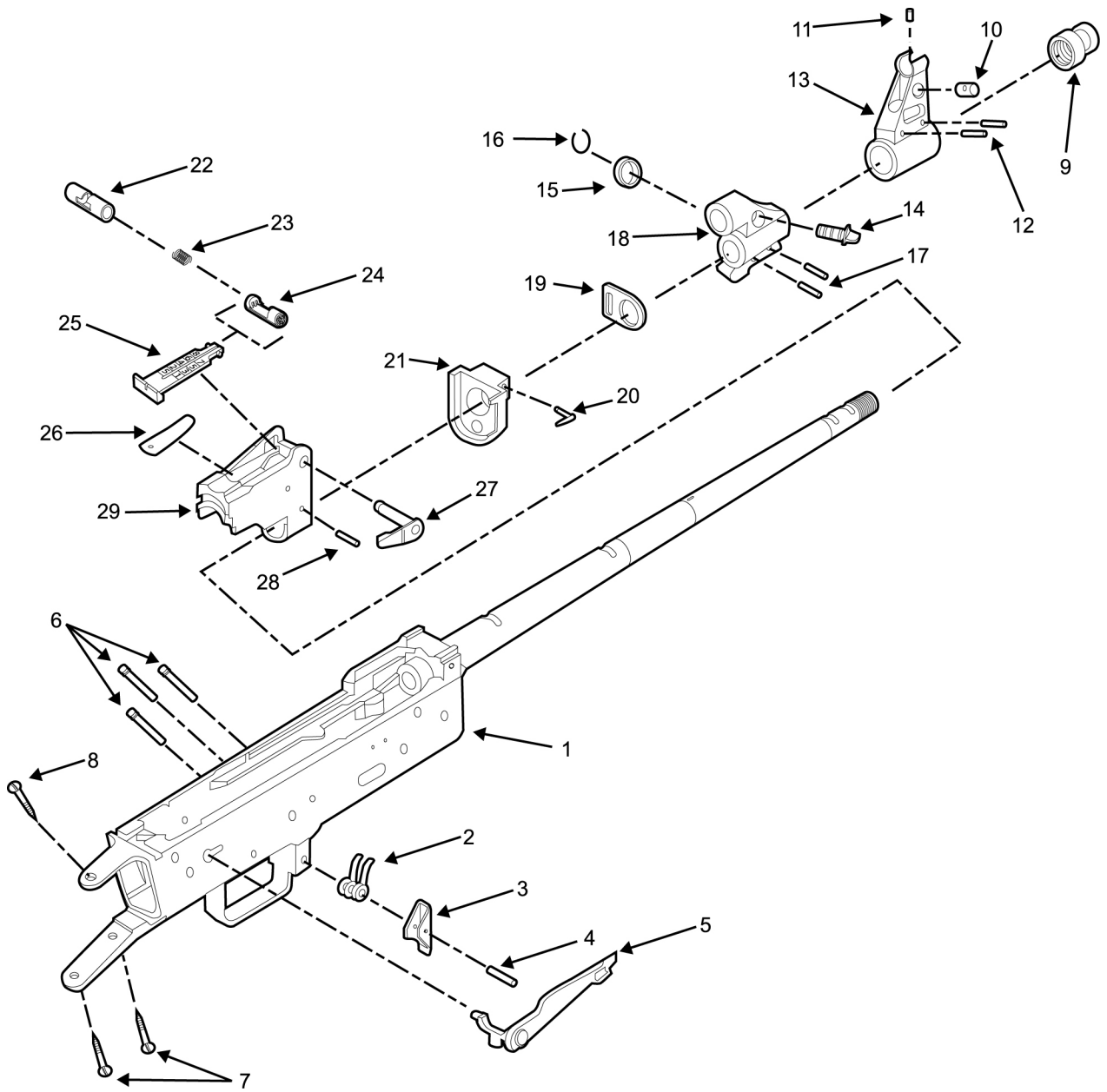


Figure 2. Receiver Assembly.

Table 2. Receiver Assembly.

(1) Item No.	(2) SMR Code	(3) NSN	(4) CAGEC	(5) Part Number	(6) Description and Usable on Codes (UOC)	(7) Qty.
Figure 2. Receiver assembly						
1	PAOZZ	TBD	TBD	TBD	Receiver	1
2	PAOZZ	TBD	TBD	TBD	Spring, magazine release	1
3	PAOZZ	TBD	TBD	TBD	Release, magazine	1
4	PAOZZ	TBD	TBD	TBD	Pin, magazine release	1
5	PAOZZ	TBD	TBD	TBD	Lever, selector	1
6	PAOZZ	TBD	TBD	TBD	Pin, retaining, trigger assembly	3
7	PAOZZ	TBD	TBD	TBD	Screw, buttstock, lower	2
8	PAOZZ	TBD	TBD	TBD	Screw, buttstock, upper	1
9	PAOZZ	TBD	TBD	TBD	Protector, thread	1
10	PAOZZ	TBD	TBD	TBD	Drum, windage, front sight	1
11	PAOZZ	TBD	TBD	TBD	Post, front sight	1
12	PAOZZ	TBD	TBD	TBD	Pin, base, front sight	2
13	PAOZZ	TBD	TBD	TBD	Base, front sight	1
14	PAOZZ	TBD	TBD	TBD	Selector, gas	1
15	PAOZZ	TBD	TBD	TBD	Collar, gas	1
16	PAOZZ	TBD	TBD	TBD	Clip, "C"	1
17	PAOZZ	TBD	TBD	TBD	Pin, gas block	2
18	PAOZZ	TBD	TBD	TBD	Block, gas	1
19	PAOZZ	TBD	TBD	TBD	Swivel, sling, front	1
20	PAOZZ	TBD	TBD	TBD	Lever, locking, lower handguard ring	1
21	PAOZZ	TBD	TBD	TBD	Ring, lower handguard	1
22	PAOZZ	TBD	TBD	TBD	Slide, rear sight assembly	1
23	PAOZZ	TBD	TBD	TBD	Spring, slide, rear sight assembly	1
24	PAOZZ	TBD	TBD	TBD	Catch, slide, rear sight assembly	1
25	PAOZZ	TBD	TBD	TBD	Sight, leaf, rear sight assembly	1
26	PAOZZ	TBD	TBD	TBD	Spring, leaf, rear sight	1
27	PAOZZ	TBD	TBD	TBD	Lever, locking, upper handguard	1
28	PAOZZ	TBD	TBD	TBD	Base, rear sight	1
29	PAOZZ	TBD	TBD	TBD	Pin, retaining, rear sight base	1
End of figure						

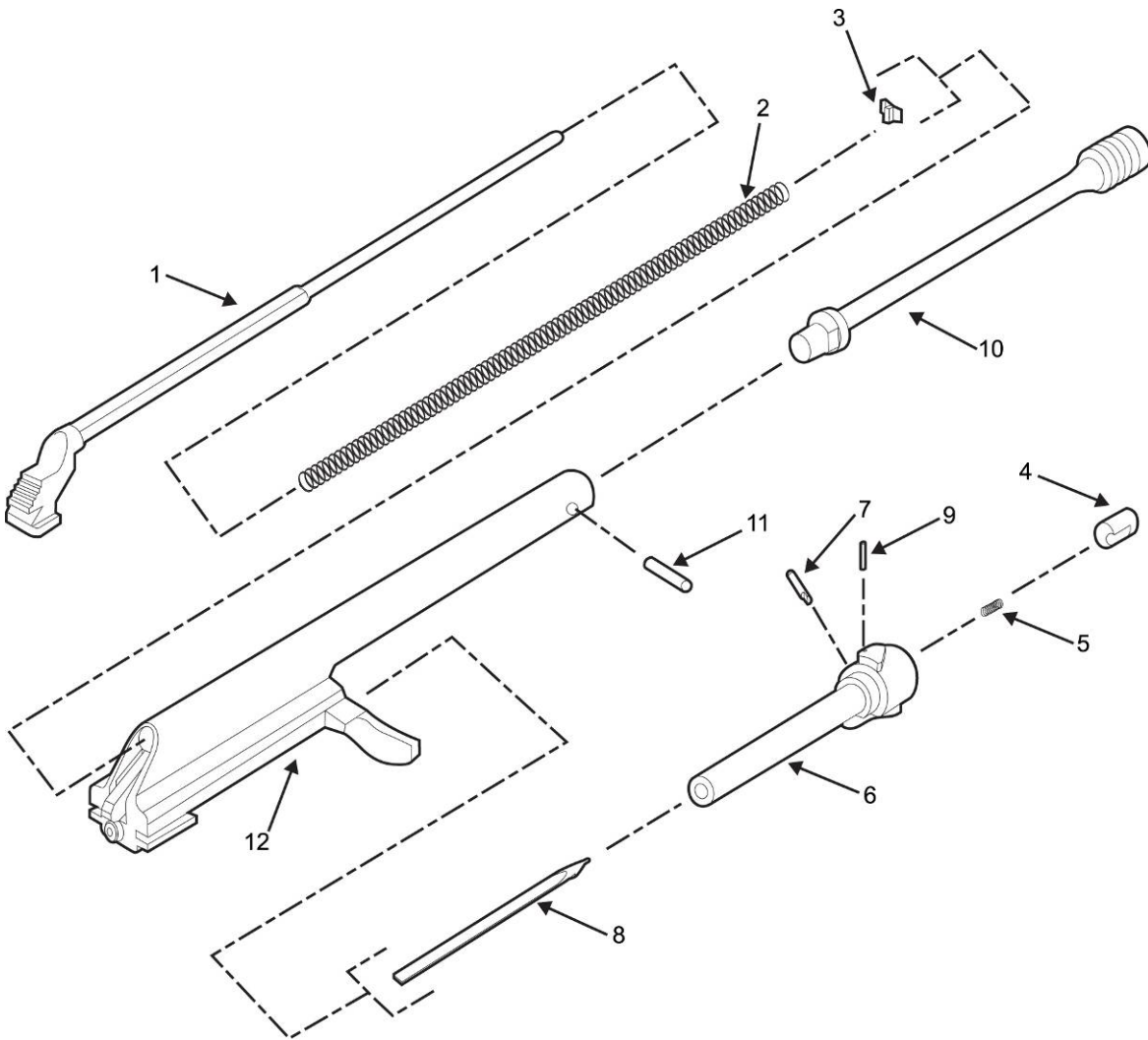


Figure 3. Recoil Spring and Guide Rod Assembly, Bolt Assembly, and Bolt Carrier Assembly.

Table 3. Recoil Spring and Guide Rod Assembly, Bolt Assembly, and Bolt Carrier Assembly.

(1) Item No.	(2) SMR Code	(3) NSN	(4) CAGEC	(5) Part Number	(6) Description and Usable on Codes (UOC)	(7) Qty.
Figure 3. Bolt carrier assembly, bolt assembly, and recoil and guide rod assembly.						
1	PAOZZ	TBD	TBD	TBD	Assembly, Recoil Spring and Guide Rod	
2	PAOZZ	TBD	TBD	TBD	Rod, guide	1
3	PAOZZ	TBD	TBD	TBD	Spring, recoil	1
4	PAOZZ	TBD	TBD	TBD	Cam, recoil spring	1
Assembly, Bolt						
5	PAOZZ	TBD	TBD	TBD	Extractor	1
6	PAOZZ	TBD	TBD	TBD	Spring, extractor	1
7	PAOZZ	TBD	TBD	TBD	Bolt	1
8	PAOZZ	TBD	TBD	TBD	Pin, retaining, extractor, grooved	1
9	PAOZZ	TBD	TBD	TBD	Pin firing	1
10	PAOZZ	TBD	TBD	TBD	Pin, retaining, firing pin	1
Assembly, bolt carrier						
11	PAOZZ	TBD	TBD	TBD	Piston, gas	1
12	PAOZZ	TBD	TBD	TBD	Pin, retaining, gas piston	1
13	PAOZZ	TBD	TBD	TBD	Carrier, bolt	1
End of figure						

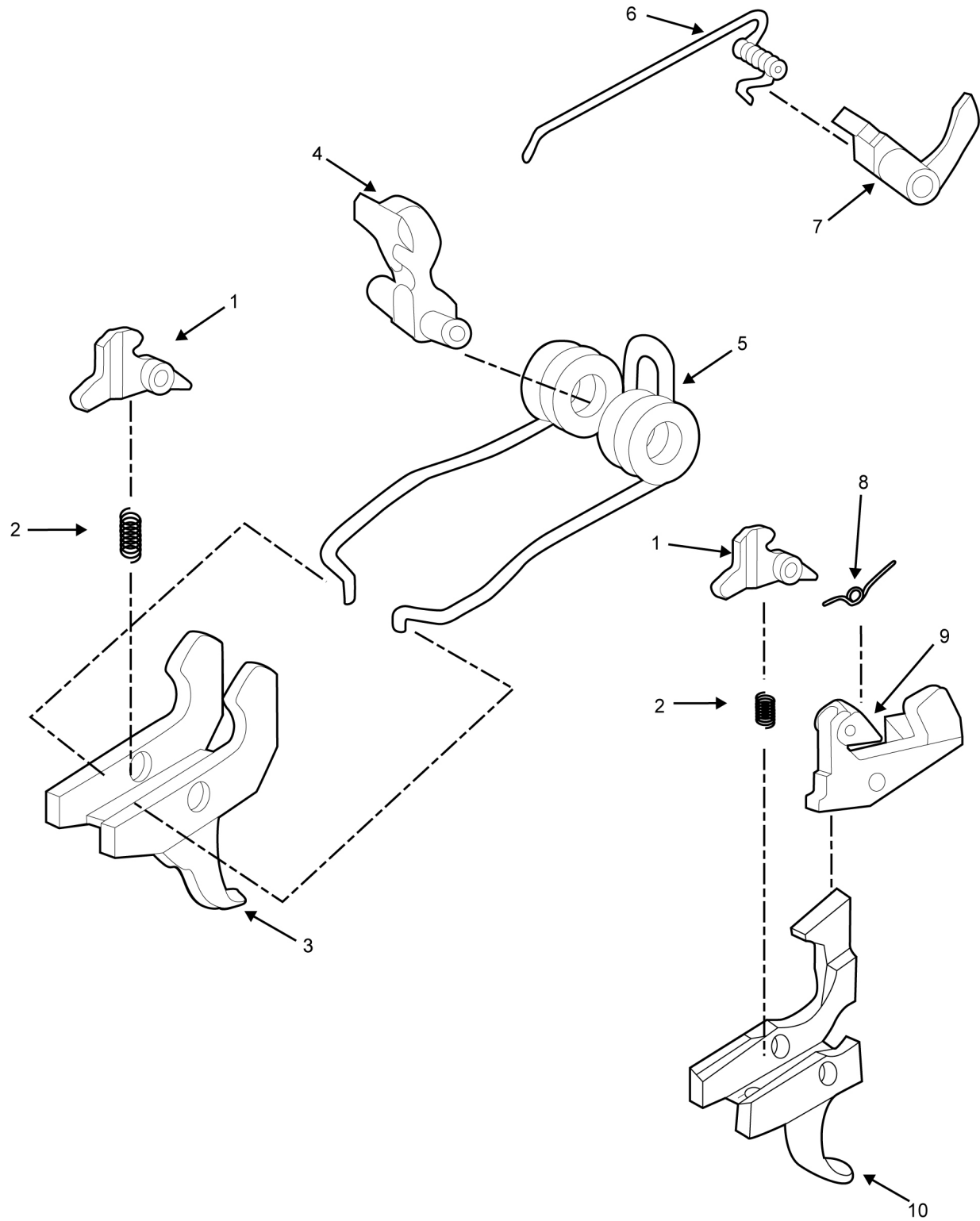


Figure 4. Trigger Assembly.

Table 4. Trigger Assembly.

(1) Item No.	(2) SMR Code	(3) NSN	(4) CAGEC	(5) Part Number	(6) Description and Usable on Codes (UOC)	(7) Qty.
Figure 4. Trigger assembly.						
1	PAOZZ	TBD	TBD	TBD	Disconnecter	1
2	PAOZZ	TBD	TBD	TBD	Spring, disconnecter	1
3	PAOZZ	TBD	TBD	TBD	Trigger, hooked, double	1
4	PAOZZ	TBD	TBD	TBD	Hammer	1
5	PAOZZ	TBD	TBD	TBD	Spring, hammer	1
6	PAOZZ	TBD	TBD	TBD	Spring, auto sear	1
7	PAOZZ	TBD	TBD	TBD	Sear, auto	1
8	PAOZZ	TBD	TBD	TBD	Spring, interrupter	1
9	PAOZZ	TBD	TBD	TBD	Interrupter	1
10	PAOZZ	TBD	TBD	TBD	Trigger, hooked, single	1
End of figure						

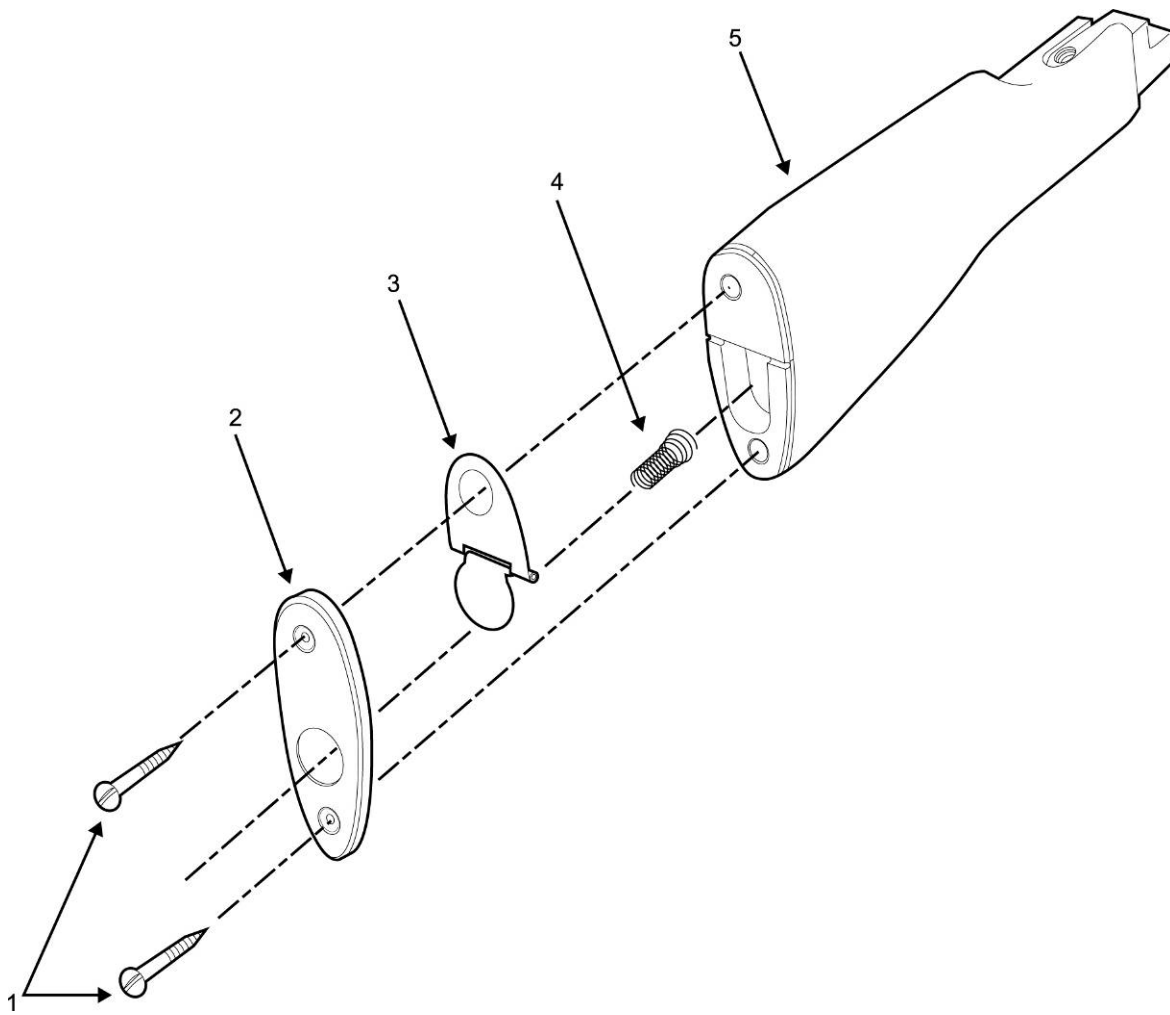


Figure 5. Fixed Buttstock Assembly

Table 5. Fixed Buttstock Assembly.

(1) Item No.	(2) SMR Code	(3) NSN	(4) CAGEC	(5) Part Number	(6) Description and Usable on Codes (UOC)	(7) Qty.
Figure 5. Fixed buttstock assembly.						
1	PAOZZ	TBD	TBD	TBD	Screw, buttplate	2
2	PAOZZ	TBD	TBD	TBD	Buttplate	1
3	PAOZZ	TBD	TBD	TBD	Trapdoor, buttplate	1
4	PAOZZ	TBD	TBD	TBD	Spring, buttplate	1
5	PAOZZ	TBD	TBD	TBD	Buttstock, fixed	1
End of figure						

END OF WORK PACKAGE

INTENTIONALLY BLANK

INDEX

Subject *WP Sequence No. – Page No.*

A

Abbreviations and Acronyms, List of..... 0001 00-2
 Auxiliary Equipment - General 0022 00-1

B

Bolt Assembly 0012 00-1
 Bolt Carrier Assembly and Bolt Assembly 0011 00-1

D

Disassembly of Weapon 0010 00-1

C

Caution Summary f
 Cleaning Instructions, General..... 0009 00-1

E

Equipment Description and Data 0002 00-1
 Expendable and Durable Items List 0024 00-1

F

Final Inspection and Function Test 0020 00-1
 Fixed Buttstock Assembly 0015 00-1
 Function Check 0017 00-1

G

Gaging Procedures 0021 00-1
 General Information 0001 00-1
 General Maintenance Instructions 0009 00-1

H

How to Use iii

L

List of Abbreviations and Acronyms..... 0001 00-2
 Lubrication Instructions, General 0009 00-4

INDEX

Subject

WP Sequence No. – Page No.

P

Preventive Maintenance Checks and Services (PMCS), Including
 Lubrication Instructions, 0008 00-1
 Principles of Operation 0003 00-1

R

Rear Sight Assembly 0014 00-1
 Reassembly of Weapon..... 0016 00-1
 Receiver Assembly 0013 00-1
 References 0023 00-1
 Repair Parts List (RPL) 0027 00-1
 Repair Parts List (RPL) Introduction 0026 00-1

S

Service Upon Receipt 0007 00-1
 Side Folding Buttstock Assembly 0013 00-16
 Storage 0019 00-1
 Stowage 0018 00-1

T

Tool Identification List (Includes Special Tools)..... 0025 00-1
 Troubleshooting Introduction 0004 00-1
 Troubleshooting Procedures..... 0006 00-1
 Troubleshooting Symptom Index 0005 00-1

U

Under Folding Buttstock Assembly 0013 00-13

W

Warning Summarya